

Secustos SQ80 series

Multi-frequency access control readers

USER MANUAL



TABLE OF CONTENTS

1	INTRODUCTION.....	3
1.1	ABOUT THIS MANUAL	3
1.2	SCOPE OF DELIVERY	3
1.2.1	COMPONENTS	3
1.2.2	ACCESSORIES	4
1.3	SESAMSEC SUPPORT	4
2	INTENDED USE.....	5
3	SAFETY INFORMATION	6
4	TECHNICAL DATA	9
4.1	TECHNICAL SPECIFICATIONS	9
4.2	FIRMWARE	9
4.3	ANTENNAS	10
5	INSTALLATION	11
5.1	GETTING STARTED	11
5.2	INSTALLATION OVERVIEW	12
5.3	ELECTRICAL CONNECTION	13
5.3.1	CONNECTOR ASSIGNMENT	13
5.3.2	ADDITIONAL CABLE INFORMATION.....	13
5.4	MECHANICAL INSTALLATION.....	14
5.4.1	INSTALLATION DIRECTLY ON THE WALL.....	14
5.4.2	INSTALLATION WIT FLUSH-MOUNTED BOX.....	15
6	SETTINGS	16
6.1	GENERAL SETTINGS.....	16
6.2	CONFIGURATION WITH SECUSTOS SECO APP	16
6.3	CONFIGURATION WITH USB CABLE	16
6.4	CONNECTION TO AN ACCESS CONTROLLER	17
6.4.1	LINE TOPOLOGY	17
6.4.2	STAR TOPOLOGY	17
7	COMPLIANCE STATEMENTS.....	19
7.1	EU.....	19
7.2	FCC.....	19
7.3	ISED /ISDE CANADA.....	20
7.4	CHINA (PRC) / 中华人民共和国.....	20
7.5	TAIWAN / 臺灣.....	22

7.6 UNITED KINGDOM	22
APPENDIX.....	23
A – RELEVANT DOCUMENTATION.....	23
B – TERMS AND ABBREVIATIONS	23
C – REVISION HISTORY.....	24

1 INTRODUCTION

1.1 ABOUT THIS MANUAL

This manual is intended for users and installers. It enables a safe and appropriate handling of the product and it gives a general overview, as well as important technical data and safety information about the product. Before installing and using the product, the users and installers should read and understand the content of this manual.

For the sake of better understanding and readability, this manual might contain exemplary pictures, drawings and other illustrations. Depending on your product configuration, these pictures might differ from the actual design of your product.

The original version of this manual has been written in English. Wherever the manual is available in another language, it is considered as a translation of the original document for information purposes only. In case of discrepancy, the original version in English will prevail.

1.2 SCOPE OF DELIVERY

1.2.1 COMPONENTS

Your Secustos SQ80 access control reader is delivered as a kit with the following components:

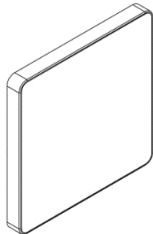
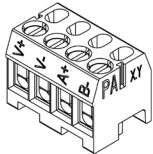
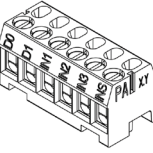
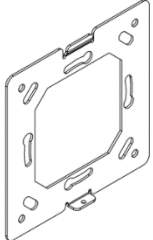
	<p>Secustos SQ80 reader</p>	<p>All Secustos SQ80 readers are equipped ex-works with one 4-pin (X1) and one 6-pin (X2) connector. Depending on the product configuration, access control readers of the Secustos SQ80 series are available with or without keypad, in a silver or gray housing.</p>
	<p>4-pin connector (X1)</p>	
	<p>6-pin connector (X2)</p>	
	<p>Mounting plate</p>	<p>The mounting plate delivered with the kit enables to fix the Secustos SQ80 reader on a wall. It must be fixed directly to the wall or on a flush-mounted box with 2 to 4 screws* *Not part of the delivery (screws are generally available on site)</p>



Fixing screw
(countersunk screw with
cross recess, M2x5)

The fixing screw delivered with the kit is intended to fix the Secustos SQ80 reader on the mounting plate. Due to its small size and inconspicuousness, particular attention should be given to the screw when unpacking the kit, as the screw might easily fall down and get lost.



Installation guide

The installation guide delivered with the product gives a short description of the installation options. Please note that the installation guide does **not** replace the user manual!

1.2.2 ACCESSORIES

Depending on your product configuration, the product can be delivered with the following accessories:

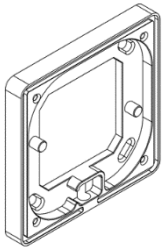

Mounting frame*

Additional frame required for on-wall installation. The mounting frame is delivered with 4 fixing screws (ISO 7046-1 stainless steel A2 M3x6) and 2 rubber seals on each side of the frame.

Part no.:
T4SA-QWF1SL (mounting frame, silver)
T4SA-QWF1GY (mounting frame, gray)
T4SX-MECH 003 (fixing screws)



USB maintenance and
configuration cable

sesamsec product-specific USB cable intended for maintenance and configuration purposes only. Particular attention should be given when plugging the USB cable in and out of the Secustos SQ80 reader.

Part no.: CAB-J4MSBAMSB150

* In order to comply with the UL certification requirements, the mounting frame **must** always be used when installing the reader outside. Any failure to meet this requirement will void the UL certification of the product.

1.3 SESAMSEC SUPPORT

In case of any technical questions, refer to the sesamsec website (www.sesamsec.com) or contact sesamsec technical support at support@sesamsec.com

In case of questions regarding your product order, contact your Sales representative or sesamsec customer service at info@sesamsec.com

2 INTENDED USE

Secustos SQ80 is a product family of access control readers based on RFID technology. The readers give the user the possibility to read more than 60 RFID technologies from low (125 kHz) and high (13.56 MHz) frequency bands. Many mobile use cases can be facilitated with their NFC and, optionally, BLE functions, like authentication and data communication.

All readers are for both indoor and outdoor use in environmental conditions according to the respective product data sheets and installation instructions given in this manual.

Any use other than the intended use described in this section, as well as any failure to comply with the safety information given in this document, is considered improper use. sesamsec excludes any liability in case of improper use or faulty product installation.

3 SAFETY INFORMATION

Transport and storage

- Observe carefully the transport and storage conditions described on the product packaging or other relevant product documents (e.g. data sheet).

Unpacking and installation

- Before unpacking and installing the product, this user manual and all relevant installation instructions must be read carefully and understood.
- After unpacking the product, check that all components have been delivered according to your order and delivery note.
Contact sesamsec if your kit is not complete.
- The following measures must be checked prior to any product installation:
 - Make sure that the mounting location and tools used for the installation are appropriate and safe. In addition, make sure that the cables intended to be used for the installation are appropriate. Refer to Chapter “Installation” for more information.
 - In case the product is installed outside, check if any further installation steps are required (e.g. sealing of cables or housing). Refer to Chapter “Installation” for more information.
 - The product is an electrical device made of sensitive materials (e.g. glass housing). Check all product components and accessories for any damage.
A damaged product or component may not be used for the installation.
 - **Life-threatening hazard in the event of fire**
A faulty or improper installation of the product might cause a fire and lead to death or severe injuries.
Check that the mounting location is equipped with appropriate safety installations and devices, like a smoke alarm or fire extinguisher.
 - **Life-threatening hazard due to electrical shock**
Make sure that there is no voltage on the wires before starting with the electrical wiring of the product and check that power is turned off by testing the power supply of each wire.
Power to the reader supply should be applied only after the installation has been completed.
 - Make sure that the product is installed in accordance with local electrical standards and regulations and observe general safety measures.
 - Risk of property damage due to transient overvoltages (surges)
Transient overvoltages imply short-duration voltage peaks that might result in system breakdown or significant damages of electrical installations and devices.
sesamsec recommends the installation of appropriate Surge Protection Devices (SPD) by a qualified and authorized personnel.
 - sesamsec also recommends the installers to follow general ESD protective measures during the installation of the product.

Please also refer to the safety information in Chapter “Installation”.

- The product might show sharp edges or corners and requires a particular attention during the unpacking and installation.
Unpack the product carefully and do not touch any sharp edges or corners, or any sensitive components on the product. If necessary, wear safety gloves.

- In order to comply with the applicable RF exposure requirements, the product should be installed and operated with a minimum distance to any user's/nearby person's body at all times. Refer to Chapter "Compliance statements" for further information about RF exposure compliance.
- In case the product is equipped with a cable, do not twist or pull the cable.
- In case of an on-wall or in-wall installation, the product must be installed in conformity with applicable local regulations.
Observe the minimum installation height and other regulations applicable in the region in which the product is installed.
- The product is an electronic product whose installation requires specific skills and expertise.
The installation of the product should be done by a trained and qualified personnel only.

Handling

- Depending on your product configuration, the product might be equipped with one or more light-emitting diodes (LED).
Avoid direct eye contact with the blinking or steady light of the light-emitting diodes.
- The product has been designed for a use under specific conditions, e.g. in a specific temperature range (refer to the product data sheet).
Any use of the product under different conditions might damage the product or alter its reading performance.
- The use of other RFID readers or reader modules in direct vicinity to the product, or in combination with the product might damage the product or alter its reading performance. In case of doubts, contact sesamsec for more information.
- The user is liable for the use of spare parts or accessories other than the ones sold or recommended by sesamsec.
sesamsec excludes any liability for damages or injuries resulting from the use of spare parts or accessories other than the ones sold or recommended by sesamsec.
- In case the product is equipped with a cable, the cable may not be replaced or extended.
sesamsec excludes any liability for damages or injuries resulting from a use of the product with a cable extension or a replaced cable.
- Like most electronic devices, RFID systems generate electromagnetic waves that can vary in amplitude and frequency. It is generally known and accepted that some RFID devices might potentially interfere with personal medical devices, like pacemakers or hearing aids.
The access control readers of the Secustos SQ80 series fulfill general radio and EMC requirements. However, users with a pacemaker or any other medical device should use the Secustos SQ80 readers carefully and refer to the information given by the manufacturer of their medical devices before using the readers.

Maintenance and cleaning

- Any repair or maintenance work should be done by a trained and qualified personnel only.
Do not allow any repair or maintenance work on the product by an unqualified or unauthorized third party.
- **Life-threatening hazard due to electrical shock**
Before any repair or maintenance work, turn the power off.

- Check the installation and electrical connection of the product in regular intervals for any signs of damage or wear. Should any damage or wear be noticed, contact sesamsec or a trained and qualified personnel for repair or maintenance work.
- The product does not need any special cleaning. However, the housing may be carefully cleaned up with a soft, dry cloth and a non-aggressive or non-halogenated cleaning agent on the outer surface only.
Make sure that the used cloth and cleaning agent do not damage the product or its components (e.g. label(s)).

Disposal

- The product must be disposed of in accordance with the EU directive on waste electrical and electronic equipment (WEEE) or any applicable local regulations.

Product modifications

- The product has been designed, manufactured and certified as defined by sesamsec.
Any product modification without prior written approval from sesamsec is prohibited and considered improper use of the product. Unauthorized product modifications may also result in the loss of product certifications.

If you are unsure about any part of the safety information above, contact sesamsec support.

Any failure to comply with the safety information given in this document is considered improper use. sesamsec excludes any liability in case of improper use or faulty product installation.

4 TECHNICAL DATA

4.1 TECHNICAL SPECIFICATIONS



Secustos SQ80 K LEGIC (left) and Secustos SQ80 LEGIC (right)
(exemplary illustrations)

FREQUENCIES	125 KHZ (LF) / 13.56 MHZ (HF) / 2.4 GHZ (BLE)
ANTENNAS	Integrated
HOUSING	Metal frame and glass front, potted housing Available in 2 colors (silver or gray)
DIMENSIONS (L X W X H)	Reader frame only (mounted): approx. 86.00 x 86.00 x 8.25 mm / 3.38 x 3.38 x 0.33 inch Rear connector height: approx. 8.00 mm / 0.31 inch Reader with rear connector: approx. 86.00 x 86.00 x 15.90 mm / 3.38 x 3.38 x 0.62 inch Optional mounting frame: approx. 86.00 x 86.00 x 9.75 mm / 3.38 x 3.38 x 0.38 inch
POWER	6.0 V - 28 V via connector X1 PS2 classified power source according to IEC 62368-1, short-circuit current < 8 A
CURRENT CONSUMPTION	Max. 300 mA @ 6.0 V
TEMPERATURE RANGE	Operating: -20 °C up to +60 °C (-4 °F up to +140 °F) Storage: -20 °C up to +70 °C (-4 °F up to +158 °F)
WEIGHT	Reader, potted, with connectors and mounting plate: approx. 113 g / 3.99 oz
RELATIVE HUMIDITY	Mounted front: IP65 protected housing Transport/Storage: 5% to 95% non-condensing

4.2 FIRMWARE

Your product is delivered ex-works with a specific firmware version. Refer to the label attached to the product to find the firmware version installed ex-works.

A/B1.50/NCD4.70/STD2.02/B/BT1.07EL
(exemplary firmware)

4.3 ANTENNAS

Both Secustos SQ80 K LEGIC and Secustos SQ80 LEGIC readers contain an RFID module equipped with the following antennas:

HF antenna (13.56 MHz)

Dimensions: approx. 42.00 x 25.00 mm (1.65 x 0.98 inch)

Number of turns: 4

LF antenna (125 kHz)

Outer diameter: max. 16.30 mm (0.64 inch)

Number of turns: 144

BLE (2.4 GHz)

Integrated BLE module

5 INSTALLATION

5.1 GETTING STARTED

Before starting with the installation of a Secustos reader, the following measures must be checked:

- Make sure you have read and understood all safety information given in Chapter “Safety information”.
- Make sure that there is no voltage on the wires and check that power is turned off by testing the power supply of each wire.
- Make sure that all tools and components required for the installation are available and appropriate.
- Make sure that the installation site is appropriate for the installation of the reader. In particular, check that the temperature of the installation site is within the operating temperature range given in the Secustos technical documentation and make sure that the wall used for the installation is appropriate. In some cases, the wall material might not be suitable for a safe and durable installation, or it might require specific mounting screws (e.g. wall made out of silicon or drywall). Furthermore, some materials might interfere with the RFID antennas of the reader and reduce its reading performance (e.g. metallic surfaces). Contact sesamsec for more information.
- The recommended installation height for a standard installation is 110 cm from the ground. However, in some cases (e.g. wheelchair access, local regulations, etc.), the actual installation height on site might differ from the recommended height. Please also note the maximum wall mounting height of 200 cm from the ground.
- In case of power lines, make sure that the minimum distance between the connection cable of the reader and the next power line is 10 cm.
- In case other RFID devices are already installed on site, or if several Secustos readers must be installed on the same site, observe a minimum distance of 30 cm between all readers and devices in order to achieve the best reading performance for each reader. Should two readers be installed in the same location (e.g. on each side of a wall, next to a door), the wall thickness should also be at least 30 cm to prevent a loss of performance of both readers.

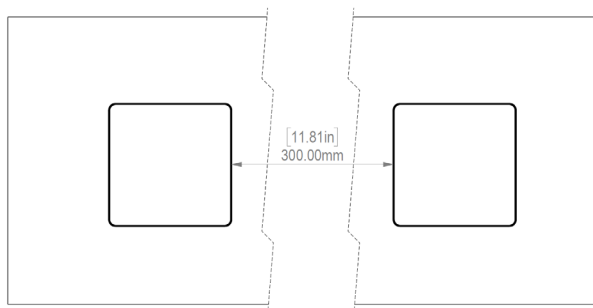

Example 1:
installation of 2 readers next to each other

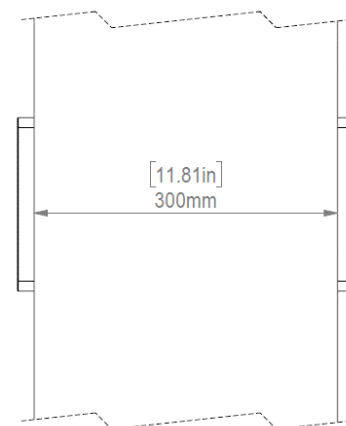

Example 2:
installation of 2 readers on each side of a wall (i.e. inside/outside)

- When installing the reader, do not cover the top left corner of the RFID module (i.e. top right corner when the reader is fixed on the wall), as it would disable both proximity and ambient light sensors.



proximity and ambient light sensors (blue frame)
front view

- The protective film on the housing front should only be removed after complete installation of the reader.

5.2 INSTALLATION OVERVIEW

The illustration below gives an overview on an exemplary installation of a Secustos SQ80 access control reader:

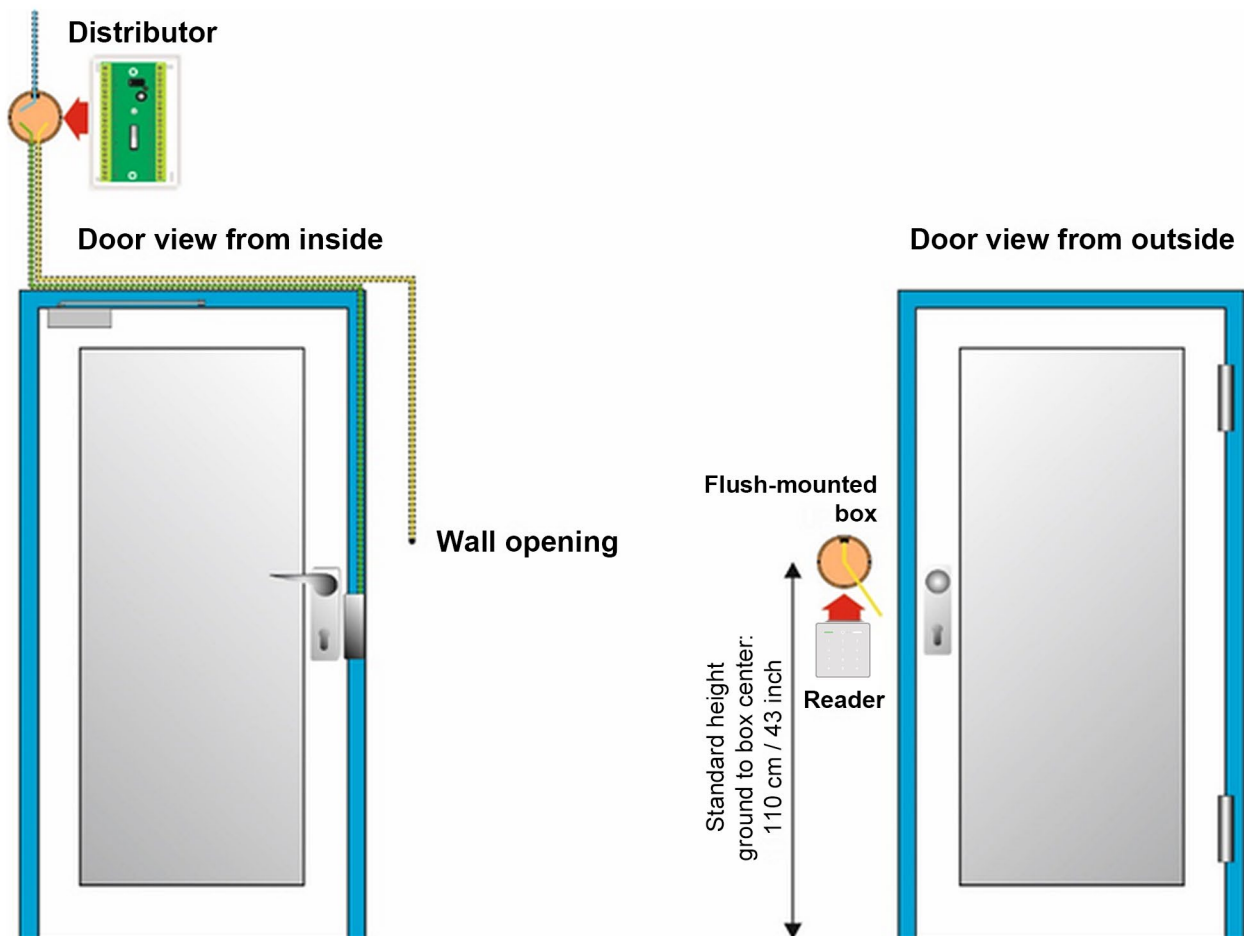

5.3 ELECTRICAL CONNECTION

5.3.1 CONNECTOR ASSIGNMENT

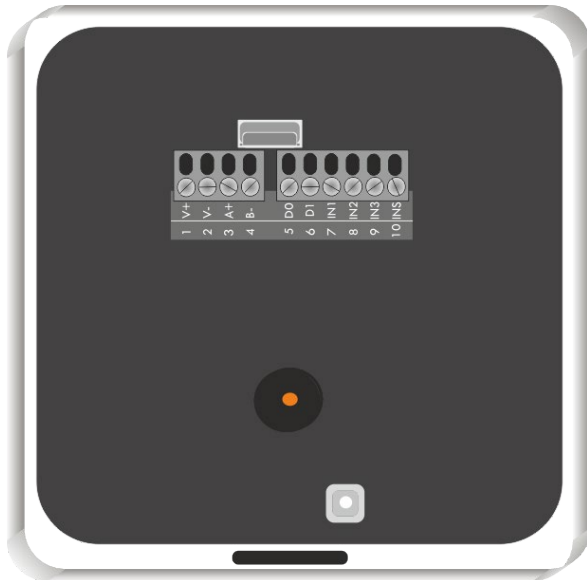

Drawing – RFID module contained in Secustos SQ80 readers

Power supply

V+	Input voltage 6 – 28 V
V-	Ground

Data transfer

A+	RS-485, cable length: max. 1000 m
B-	RS-485, cable length: max. 1000 m
D0	Wiegand D0, cable length: max 200 m*
D1	Wiegand D0, cable length: max 200 m*
IN1	Digital input 1, cable length: max 200 m*
IN2	Digital input 2, cable length: max 200 m*
IN3	Digital input 3, cable length: max 200 m*
INS	Digital input S (for external Sabotage switch), optional if sabotage button is not available on the reader, cable length: max 200 m*

* Cable routing requirements: twisted pair cabling (D0/GND, D1/GND).

Maintenance / Configuration

USB	4-pin USB connector, 1.25 mm pitch (for maintenance and configuration purposes only)
-----	--

5.3.2 ADDITIONAL CABLE INFORMATION

Typical installation cables are:

JY(ST)Y 4x2x0.6 for distance between devices \leq 25 m

JY(ST)Y 4x2x0.8 for distance between devices $>$ 25 m

Alternatively, any other appropriate cables that meet the prerequisites of RS-485 installations and wirings can be used.

In case of long cables, voltage drops might lead to a breakdown of the readers. To prevent such malfunctions, it is recommended to wire the ground (V-) and input voltage (V+) with two wires each.

In addition, the installation cable used to connect the controller must contain a cable shield and/or a drain wire with PE connection.

The cable shield/drain wire may not be connected to the reader, but only to the controller. Otherwise, it could lead to a potential difference.

5.4 MECHANICAL INSTALLATION



The Secustos mounting frame (refer to Chapter “Accessories”) is an additional component required for on-wall installation. In order to comply with the UL certification requirements, the mounting frame **must** always be used when installing the reader outside. Any failure to meet this requirement will void the UL certification of the product.

5.4.1 INSTALLATION DIRECTLY ON THE WALL

1. Fix the mounting frame to the wall as described below:

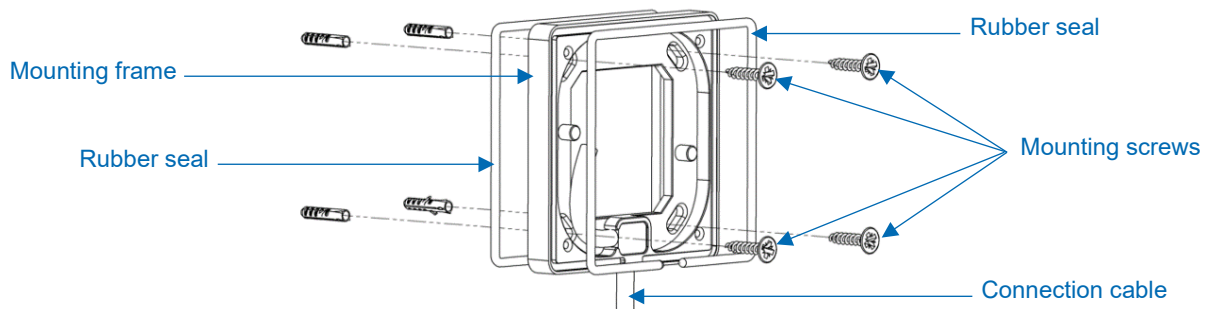

2. The mounting frame is equipped with a cable inlet on its bottom side, which also serves as a cable strain relief. Optionally, the cable inlet can be sealed with silicone.

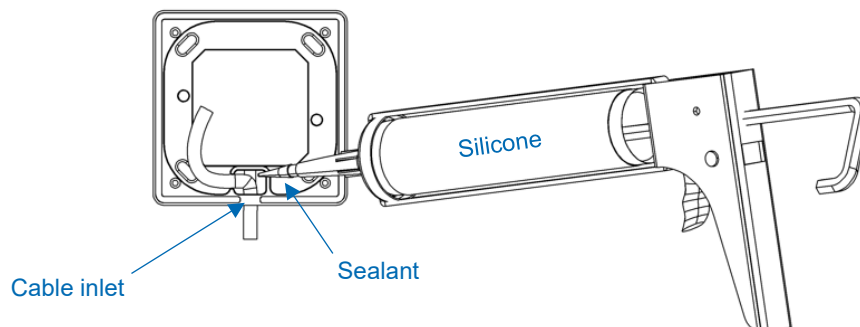

3. Finally, attach the mounting plate to the mounting frame, and the reader to the mounting plate as described below:

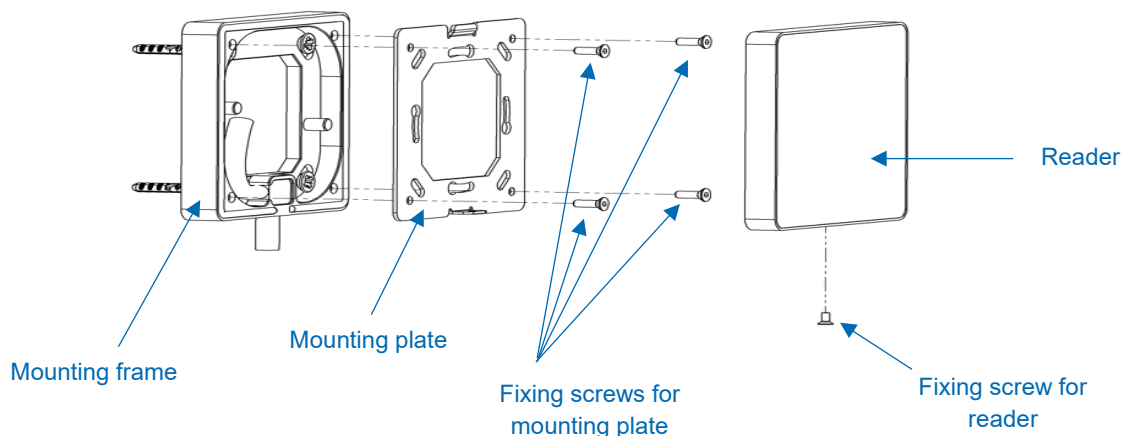

5.4.2 INSTALLATION WITH FLUSH-MOUNTED BOX

1. Attach the mounting plate to the flush-mounted box, and the reader to the mounting plate as described below:

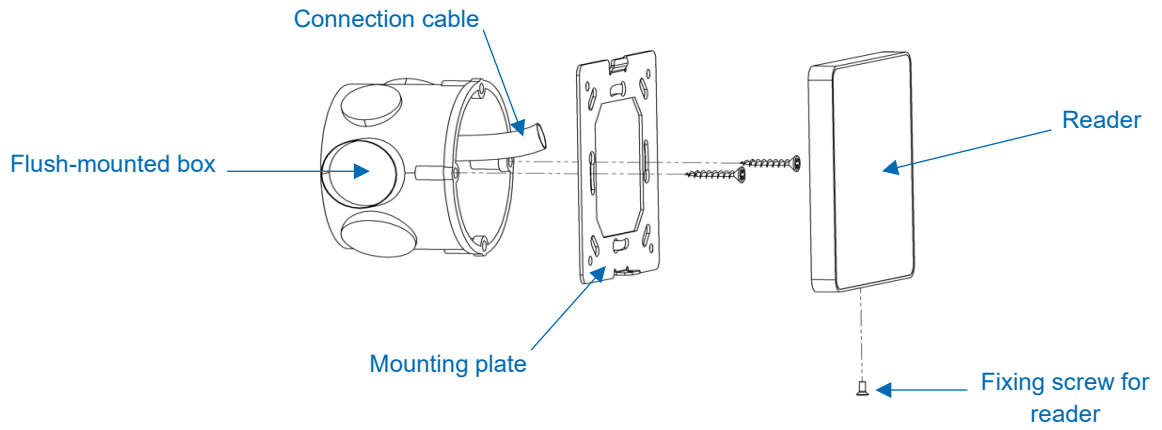

6 SETTINGS

6.1 GENERAL SETTINGS

By default, the reader is delivered ex-works with the following settings:

- OSDP: 9600 baud
- Address: 0
- Terminating resistors: off

A customer-specific configuration is also possible by changing the device settings with the sesamsec Seconfig tool.

6.2 CONFIGURATION WITH SECUSTOS SECO APP

The reader configuration with the Secustos Seco app requires an NFC-enabled mobile device (e.g. smartphone or tablet) with Android operating system (from Android 4.0). Seco must be downloaded from the Google Play Store and installed on the mobile device. Once the app has been installed, it is possible to set parameters on the mobile device and transmit them subsequently on the reader via NFC.

6.3 CONFIGURATION WITH USB CABLE

The reader can also be configured using the sesamsec specific USB cable (refer to Chapter “Accessories”) and the sesamsec Seconfig tool.

To do so, proceed as follows:

1. Connect the reader to a PC with the USB cable.
Particular attention should be given when plugging the USB cable in and out of the reader, as the 4-pin USB connector is a very sensitive component. Do not twist or pull excessively on the reader and press the connector lock when plugging the cable out.
2. Open the Seconfig tool on the PC and set the reader as requested.
Refer to the Secustos technical handbook for more information about the reader settings.
3. Save your settings before closing the Seconfig tool and disconnect the reader from the PC by plugging out the USB cable carefully.

6.4 CONNECTION TO AN ACCESS CONTROLLER

6.4.1 LINE TOPOLOGY

In this configuration, the reader bus consists of one reader connected to an RS-485 controller bus. An address must be assigned to the reader and the terminating resistors of the RS-485 bus on the reader and on the controller must also be set.

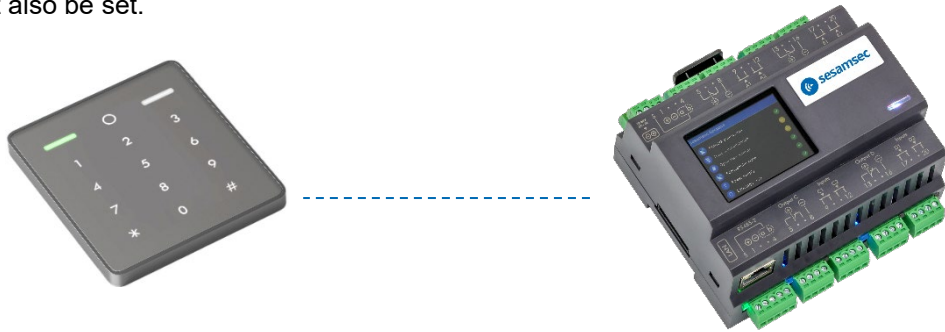

Reader
Address: 0
Terminating resistor: on

Controller
Terminating resistor: on

6.4.2 STAR TOPOLOGY

In this configuration, the reader bus consists of max. two readers, which are both connected to the same RS-485 controller bus. An address must be assigned to each reader before initial operation (e.g. Reader 1 = Address 0, Reader 2 = Address 1) as two readers with the same address would cause a conflict.

The terminating resistors of the RS-485 bus on both readers must be on, whereas the terminating resistor of the RS-485 bus on the controller must be off.

The terminating resistors of the RS-485 bus on the readers and on the controller must also be set.

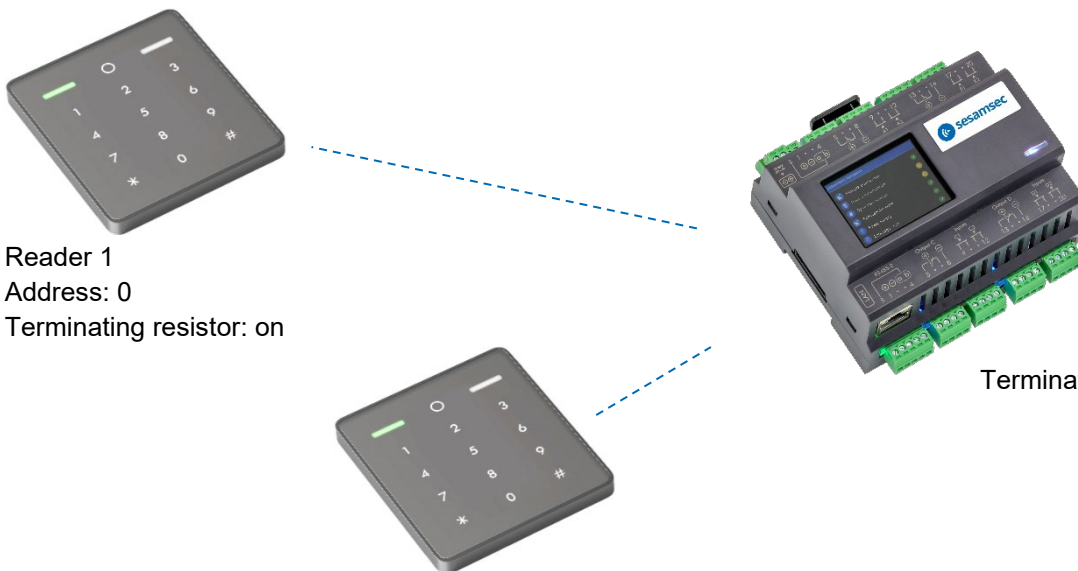

Reader 1
Address: 0
Terminating resistor: on

Reader 2
Address: 1
Terminating resistor: on

Controller
Terminating resistor: off

Please note:

- A star topology is only possible with max. two readers.
- In general, the terminating resistors of the devices opening and closing the RS-485 bus must be on. The terminating resistors of all other devices within the RS-485 bus are off.
- An RS-485 bus should contain max. two readers. Operating more than two readers would lead to a performance loss.
- A correct configuration of the controller is necessary to ensure a proper function of the readers.

7 COMPLIANCE STATEMENTS

7.1 EU

Hereby, sesamsec GmbH declares that the following products are in compliance with Directive 2014/53/EU:

- **Secustos SQ80 K LEGIC**
- **Secustos SQ80 LEGIC**

The full text of the respective EU declarations of conformity is available at the following internet address:
sesamsec.com/approvals

7.2 FCC

Secustos SQ80 K LEGIC
Secustos SQ80 LEGIC

FCC ID	2BAACSQ80KLE
--------	--------------

The device above complies with Part 15 of the FCC Rules. Operation is subject to the following two conditions:
(1) this device may not cause harmful interference, and
(2) this device must accept any interference received, including interference that may cause undesired operation. (except receivers associated with operation of a licensed radio service and stand-alone devices).

Caution

The Federal Communications Commission (FCC) warns the users that changes or modifications to the unit not expressly approved by the party responsible for compliance could void the user's authority to operate the equipment.

FCC §15.105 (b)

Note: This equipment has been tested and found to comply with the limits for a Class B digital device, pursuant to part 15 of the FCC Rules. These limits are designed to provide reasonable protection against harmful interference in a residential installation. This equipment generates, uses and can radiate radio frequency energy and, if not installed and used in accordance with the instructions, may cause harmful interference to radio communications. However, there is no guarantee that interference will not occur in a particular installation. If this equipment does cause harmful interference to radio or television reception, which can be determined by turning the equipment off and on, the user is encouraged to try to correct the interference by one or more of the following measures:

- Reorient or relocate the receiving antenna.
- Increase the separation between the equipment and receiver.
- Connect the equipment into an outlet on a circuit different from that to which the receiver is connected.
- Consult the dealer or an experienced radio/TV technician for help.

RF exposure statement

The device above complies with FCC radiation exposure limits set forth for an uncontrolled environment under the following conditions: This equipment should be installed and operated such that a minimum separation distance of 20 cm is maintained between the antenna and user's/nearby person's body at all times.

7.3 ISED /ISDE CANADA

Secustos SQ80 K LEGIC
Secustos SQ80 LEGIC

IC	30098-SQ80KLE
----	---------------

The device above contains licence-exempt transmitter(s)/receiver(s) that comply with Innovation, Science and Economic Development Canada’s licence-exempt RSS(s). Operation is subject to the following two conditions:

1. This device may not cause interference.
2. This device must accept any interference, including interference that may cause undesired operation of the device.

L’émetteur/récepteur exempt de licence contenu dans le présent appareil est conforme aux CNR d’Innovation, Sciences et Développement économique Canada applicables aux appareils radio exempts de licence. L’exploitation est autorisée aux deux conditions suivantes:

1. L’appareil ne doit pas produire de brouillage;
2. L’appareil doit accepter tout brouillage radioélectrique subi, même si le brouillage est susceptible d’en compromettre le fonctionnement.

RF exposure statement / Déclaration de conformité aux limites d’exposition humaine aux radiofréquences

The device above complies with ISED radiation exposure limits set forth for an uncontrolled environment under the following conditions: This equipment should be installed and operated such that a minimum separation distance of 20 cm is maintained between the antenna and user’s/nearby person’s body at all times.

L’appareil ci-dessus est conforme aux limites d’exposition humaine aux radiofréquences d’Innovation, Sciences et Développement économique Canada établies pour un environnement non contrôlé, dès lors que les conditions suivantes sont respectées: Le présent appareil doit être installé et utilisé à une distance minimale de 20 cm de toute personne.

7.4 CHINA (PRC) / 中华人民共和国

<p>Micropower scope of use declaration:</p> <p>Secustos SQ80 K LEGIC/Secustos SQ80 LEGIC supports transmission frequencies of 13.56 MHz and 125 kHz. The user needs to adhere to the following specifications when using the product:</p> <p>(1) The specific provisions listed in the “catalog and the technical specifications for micropower short-range radio transmission equipment” as well as the usage scenarios for the antenna type used, the functions, and the customary use of the control system, regulation, and switches must be complied with;</p> <p>Transmission power: 13.56 MHz: ≤ -6.60 dBμA/m (field strength at 10 meters, standard max value) 125 kHz: ≤ -0.60 dBμA/m (field strength at 10 meters, standard max value)</p>	<p>微功率使用规范声明：</p> <p>Secustos SQ80 K LEGIC/Secustos SQ80 LEGIC 支持 13.56MHz 和 125kHz 发射频率，用户在使用过程中，需要遵守以下要求：</p> <p>（一）符合“微功率短距离无线电发射设备目录和技术要求”的具体条款和使用场景，采用的天线类型和性能，控制、调整及开关等使用方法；</p> <p>发射功率： 13.56MHz：≤ -6.60dBμA/m (10 米处场强，准峰值) 125kHz：≤ -0.60dBμA/m (10 米处场强，准峰值)</p>
---	--

<p>Antenna: built-in antenna (cannot be removed)</p> <p>Control system, regulation, and switches: The user cannot control, regulate, or switch over the radio transmission function of the antenna.</p> <p>(2) The unauthorized modification of usage scenarios or the conditions of use, expansion of the transmission frequency range, or increase of the transmission power (including installing additional transmission power amplifiers), as well as the unauthorized modification of the transmission antenna are not allowed;</p> <p>(3) The product may not interfere in any way with any legal radio transmitters (stations) and may not offer any shielding from harmful interference;</p> <p>(4) The product must be able to tolerate interference caused by industrial, scientific, and medical (ISM) devices which radiate high frequency energy or other legal interference from radio transmitters (stations);</p> <p>(5) Should the product cause harmful interference on other legal radio transmitters (stations), product use must be discontinued immediately and suitable measures must be taken prior to using the product again in order to eliminate said interference;</p> <p>(6) When using micropower devices inside of an aircraft or radiometric observatories, or when using such devices in meteorological radar stations, satellite ground stations (including measuring and control stations, distance measuring stations, receiving stations, or navigation stations), as well as in radio transmitters (stations) used by the military and electromagnetic environment protections zones at airports, all applicable provisions of the competent authorities as well as statutory provisions, national regulations, and national standards must be complied with;</p> <p>(7) Remote controls of any kind may not be used within 5000 meters of airport runways, measured from the middle of the runway;</p> <p>(8) Ambient conditions such as temperature and voltage when using micropower devices:</p>	<p>天线：内置天线（不可拆卸）</p> <p>控制、调整及开关：用户不能控制、调制及开关此无线电发射功能</p> <p>（二）不得擅自改变使用场景或使用条件、扩大发射频率范围、加大发射功率（包括额外加装射频功率放大器），不得擅自更改发射天线；</p> <p>（三）不得对其他合法的无线电台（站）产生有害干扰，也不得提出免受有害干扰保护；</p> <p>（四）应当承受辐射射频能量的工业、科学及医疗（ISM）应用设备的干扰或其他合法的无线电台（站）干扰；</p> <p>（五）如对其他合法的无线电台（站）产生有害干扰时，应立即停止使用，并采取措施消除干扰后方可继续使用；</p> <p>（六）在航空器内和依据法律法规、国家有关规定、标准划设的射电天文台、气象雷达站、卫星地球站（含测控、测距、接收、导航站）等军民用无线电台（站）、机场等的电磁环境保护区域内使用微功率设备，应当遵守电磁环境保护及相关行业主管部门的规定；</p> <p>（七）禁止在以机场跑道中心点为圆心、半径 5000 米的区域内使用各类模型遥控器；</p> <p>（八）微功率设备使用时温度和电压的环境条件。 Secustos SQ80 K LEGIC/Secustos SQ80 LEGIC 的工作电压 6.0V-28V（X1 供电）， 工作温度-20°C~60°C， 储存温度-20°C~70°C。 用户需严格按照此温度和电压要求使用。</p>
--	---

<p>operating voltage of Secustos SQ80 K LEGIC / Secustos SQ80 LEGIC: 6.0 V – 28 V (charging via X1), operating temperature: -20 °C – 60 °C, storage temperature: -20 °C – 70 °C.</p> <p>The user must strictly adhere to these temperature and voltage specifications when using the product.</p>	
---	--

7.5 TAIWAN / 臺灣

注意!

取得審驗證明之低功率射頻器材，非經核准，公司、商號或使用者均不得擅自變更頻率、加大功率或變更原設計之特性及功能。低功率射頻器材之使用不得影響飛航安全及干擾合法通信；經發現有干擾現象時，應立即停用，並改善至無干擾時方得繼續使用。前述合法通信，指依電信管理法規定作業之無線電通信。低功率射頻器材須忍受合法通信或工業、科學及醫療用電波輻射性電機設備之干擾。

7.6 UNITED KINGDOM

The following products comply with the requirements of the UK legislations and other regulations as listed in the respective UK declarations of conformity.

- **Secustos SQ80 K LEGIC**
- **Secustos SQ80 LEGIC**

The importer is responsible for applying the following information to the packaging of the products:



- the importer company's details, including the company's name and a contact address in the United Kingdom.
- UKCA marking

APPENDIX

A – RELEVANT DOCUMENTATION

sesamsec documentation

- Installation guide Secustos SQ80 series
- Secustos SQ80 K LEGIC data sheet
- Secustos SQ80 LEGIC data sheet
- sesamsec product catalog for access control (*sesamsec Produktkatalog Zutrittskontrolle*)

external documentation

- Technical documentation related to installation site
- Optionally: Technical documentation related to host product

B – TERMS AND ABBREVIATIONS

TERM	EXPLANATION
BLE	Bluetooth Low Energy
ESD	Electrostatic discharge
HF	High frequency
LED	Light-emitting diode
LF	Low frequency
NFC	Near-field communication
PE	Protective Earth
RF	Radio frequency
RFID	Radio frequency identification
SPD	Surge Protection Device
UKCA	United Kingdom Conformity Assessed
WEEE	Waste of electrical and electronic equipment. Refers to Directive 2012/19/EU of the European Parliament and of the Council of the European Union

C – REVISION HISTORY

VERSION	CHANGE DESCRIPTION	EDITION
04	Editorial changes, chapters “Accessories”, “Technical Data”, “Mechanical Installation” and “Compliance Statements” updated	11/2023
03	Product pictures and chapters “Accessories”, “Technical Data”, “Electrical Connection” and “Compliance Statements” updated, chapter “Self-test” deleted	06/2023
02	Chapter “Compliance Statements” updated	05/2023
01	First edition	04/2023



sesamsec GmbH

Finsterbachstr. 1 • 86504 Merching • Germany
P +49 8233 79445-0 • F +49 8233 79445-20 • E-mail: info@sesamsec.com
sesamsec.com

sesamsec reserves the right to change any information or data in this document without prior notice. sesamsec declines all responsibility for the use of this product with any other specification but the one mentioned above. Any additional requirement for a specific customer application has to be validated by the customer himself at his own responsibility. Where application information is given, it is only advisory and does not form part of the specification. Disclaimer: All names used in this document are registered trademarks of their respective owners.

© 2023 sesamsec GmbH – Secustos SQ80 series user manual – DocRev04 – EN – 11/2023