



RAYSTAR

RAYSTAR Optronics, Inc.
曜凌光電股份有限公司



曜凌光電股份有限公司 Raystar Optronics, Inc.

42881台中市大雅區科雅路25號5樓
5F, No. 25, Keya Road, Daya Dist., Taichung City 42881, Taiwan
T : +886-4-2565-0761 | F : +886-4-2565-0760
sales@raystar-optronics.com | www.raystar-optronics.com

RFH1010J-AYH-LNS

SPECIFICATION

CUSTOMER:

APPROVED BY	
PCB VERSION	
DATE	

FOR CUSTOMER USE ONLY

SALES BY	APPROVED BY	CHECKED BY	PREPARED BY

Release DATE:

TFT Display Inspection Specification: <https://www.raystar-optronics.com/download/products.htm>
Precaution in use of TFT module: <https://www.raystar-optronics.com/download/declaration.htm>

Revision History

VERSION	DATE	REVISED PAGE NO.	Note
0	2020/07/14		First issue

RAYSTAR OPTRONICS

Contents

1. Module Classification Information
2. Summary
3. General Specification
4. Interface
5. Contour Drawing
6. Absolute Maximum Ratings
7. Electrical Characteristics
8. Function Description
9. Optical Characteristics
10. Reliability
11. Touch Panel Information
12. Other

2.Summary

TFT 10.1" is a color active matrix thin film transistor (TFT) liquid crystal display without polarizer. This model is composed of amorphous silicon TFT as a switching device.

This TFT LCD has a 10.1" wide (16:9) diagonally measured active display area with WVGA (1024 horizontal by 600 vertical pixel) resolution. Each pixel is divided into Red, Green, Blue dots which are arranged in vertical stripes.

RAYSTAR OPTRONICS

3. General Specifications

- Size: 10.1 inch
- Dot Matrix: 1024 RGB X 600 dots
- Module dimension: 235(W) x 143(H) x 6.65 (D) mm
- Active area: 222.72 (H) x 125.28(V) mm
- Dot pitch: 0.2175(W) x 0.2088(H) mm
- LCD type: TFT, Normally Black, Transmissive
- Interface: LVDS
- Driver IC: EK79001HN + EK73215BCGA or equivalent
- Viewing Angle: 85/85/85/85
- Aspect Ratio: 16:9
- Backlight Type: LED, Normally White
- With /Without TP: With RTP
- Surface: Anti-Glare

*Color tone slight changed by temperature and driving voltage.

4.Interface

4.1. TFT LCD MODULE

Pin No.	Symbol	Description
1	VCOM	Common voltage
2	VDD	Digital power
3	VDD	Digital power
4	NC	Not connect
5	Reset	Global reset pin. Active low to enter reset state. Suggest to connecting with an RC reset circuit for stability. Normally pull high. (R=10KΩ, C=1μF)
6	STBYB	Standby mode, normally pull high STBYB="1", normal operation STBYB="0", timing control, source driver will turn off, all output are high-Z
7	GND	Digital ground
8	RXIN0-	Negative LVDS differential data inputs
9	RXIN0+	Positive LVDS differential data inputs
10	GND	Digital ground
11	RXIN1-	Negative LVDS differential data inputs
12	RXIN1+	Positive LVDS differential data inputs
13	GND	Digital ground
14	RXIN2-	Negative LVDS differential data inputs
15	RXIN2+	Positive LVDS differential data inputs
16	GND	Digital ground
17	RXCLKN-	Negative LVDS differential clock inputs
18	RXCLKN+	Positive LVDS differential clock inputs
19	GND	Digital ground
20	RXIN3-	Negative LVDS differential data inputs
21	RXIN3+	Positive LVDS differential data inputs
22	GND	Digital ground
23	NC	Not connect
24	NC	Not connect
25	GND	Digital ground
26	NC	Not connect
27	NC	Not connect

28	SELB	6-bit/8-bit input select SELB = L , 8-bit ; SELB = H , 6-bit
29	AVDD	Analog power
30	GND	Digital ground
31	LED-	LED Cathode
32	LED-	LED Cathode
33	L/R	Left or right display control
34	U/D	Up / down display control
35	VGL	Negative power for TFT
36	NC	Not connect
37	NC	Not connect
38	VGH	Positive power for TFT
39	LED+	LED Anode
40	LED+	LED Anode

When L/R="0",set right to left scan direction.

When L/R="1",set left to right scan direction.

When U/D="0",set top to bottom scan direction.

When U/D="1",set bottom to top scan direction.

5. Contour Drawing

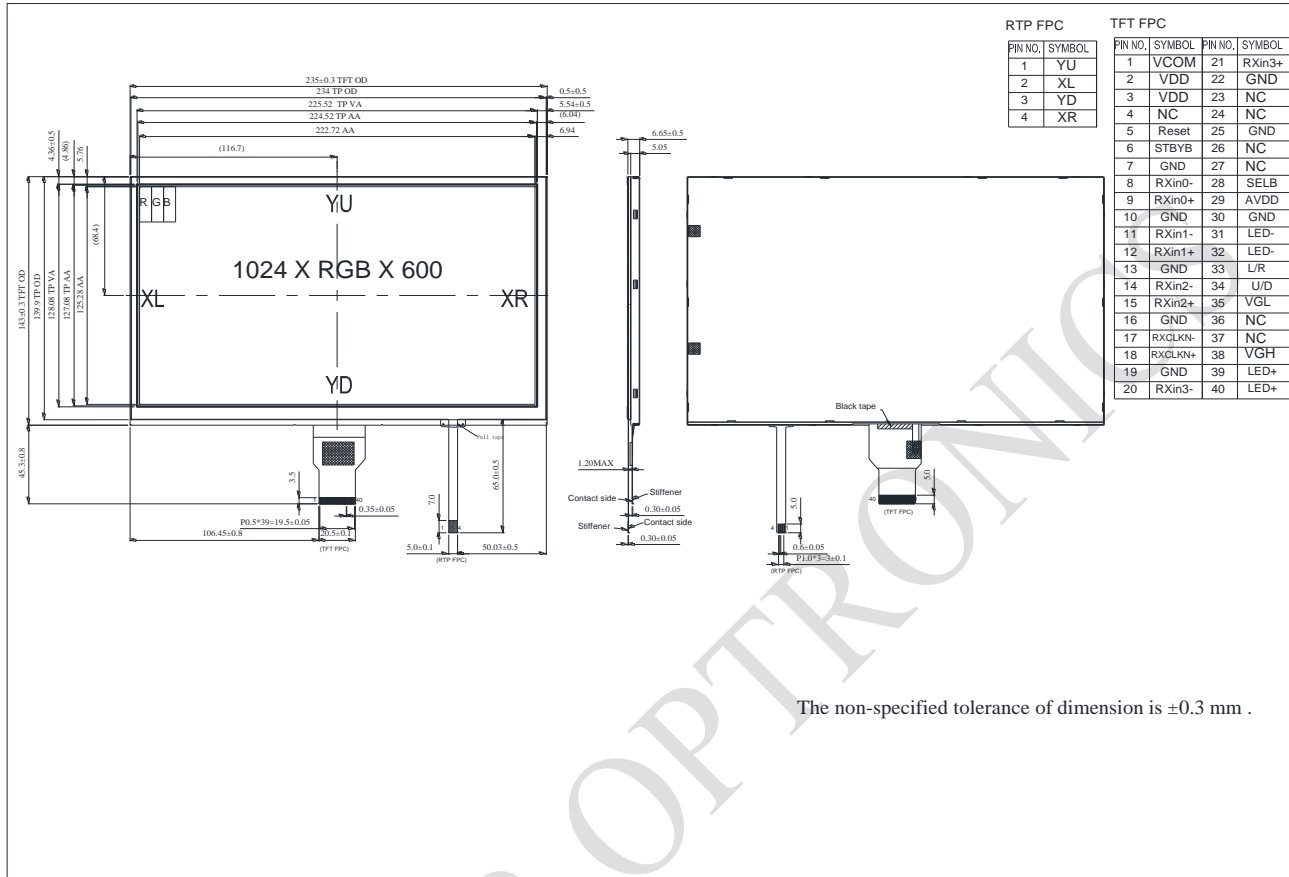

6. Absolute Maximum Ratings

Item	Symbol	Min	Typ	Max	Unit
Operating Temperature	TOP	-20	—	+70	□
Storage Temperature	TST	-30	—	+80	□

Note: Device is subject to be damaged permanently if stresses beyond those absolute maximum ratings listed above

- Temp. □60□, 90% RH MAX. Temp. >60□, Absolute humidity shall be less than 90% RH at 60□

RAYSTAR OPTRONICS

7. Electrical Characteristics

7.1. Typical Operation Conditions (At Ta = 25 °C,)

ITEM	SYMBOL	MIN	TYP	MAX	UNIT	NOTE
Digital Power Supply Voltage For LCD	VDD	3	3.3	3.6	V	Note1
Analog Power Supply Voltage	AVDD	9.89	10.2	10.5	V	-
Gate On Power Supply Voltage	VGH	19.4	20.0	20.6	V	-
Gate Off Power Supply Voltage	VGL	-10.3	-10.0	-9.7	V	-
Common Power Supply Voltage	VCOM	4.0	4.3	4.6	V	Note2
Input logic high voltage	VIH	0.7 V _{DD}	-	V _{DD}	V	Note3
Input logic low voltage	VIL	0	-	0.3 V _{DD}	V	

Note1:VDD setting should match the signals output voltage (refer to Note 3) of customer's system board.

Note 2.Please adjust VCOM to make the flicker level be minimum.

Note 3:RESET,STBYB,U/D,L/R,SELB

7.2. Current Consumption

Item	Symbol	Values			Unit	Remark
		Min.	Typ.	Max.		
Current for Driver	IGH	-	0.48	1.0	mA	VGH =20.0V
	IGL	-	1.57	2.5	mA	VGL = -10.0V
	IVDD	-	24	36	mA	VDD =3.3V
	IAVDD	-	13.7	25	mA	AVDD =10.2V

7.3. Backlight Driving Conditions

Parameter	Symbol	Min.	Typ.	Max.	Unit	Note
Supply voltage of white LED backlight	VL	10.8	12.4	14.0	V	Note 1
Current for LED backlight	IL	-	480	-	mA	
LED life time	-	50,000	-	-	Hr	Note2

Note 1 : There are 1 Groups LED

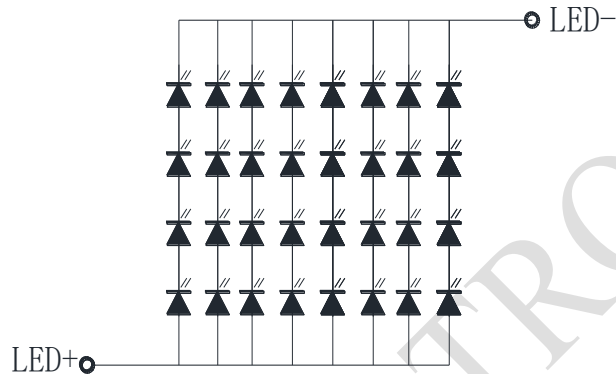

CIRCUIT DIAGRAM

Note 2 : $T_a = 25\text{ }^\circ\text{C}$

Note 3 : Brightness to be decreased to 50% of the initial value

Note 4 : The single LED lamp case

8. Function Description

8.1. Power On/Off Sequence

In order to prevent IC from power on reset fail, the rising time (TPOR) of the digital power supply VDD should be maintained within the given specifications. Refer to “AC Characteristics” for more detail on timing.

8.2. Power-On/Off Timing Sequence

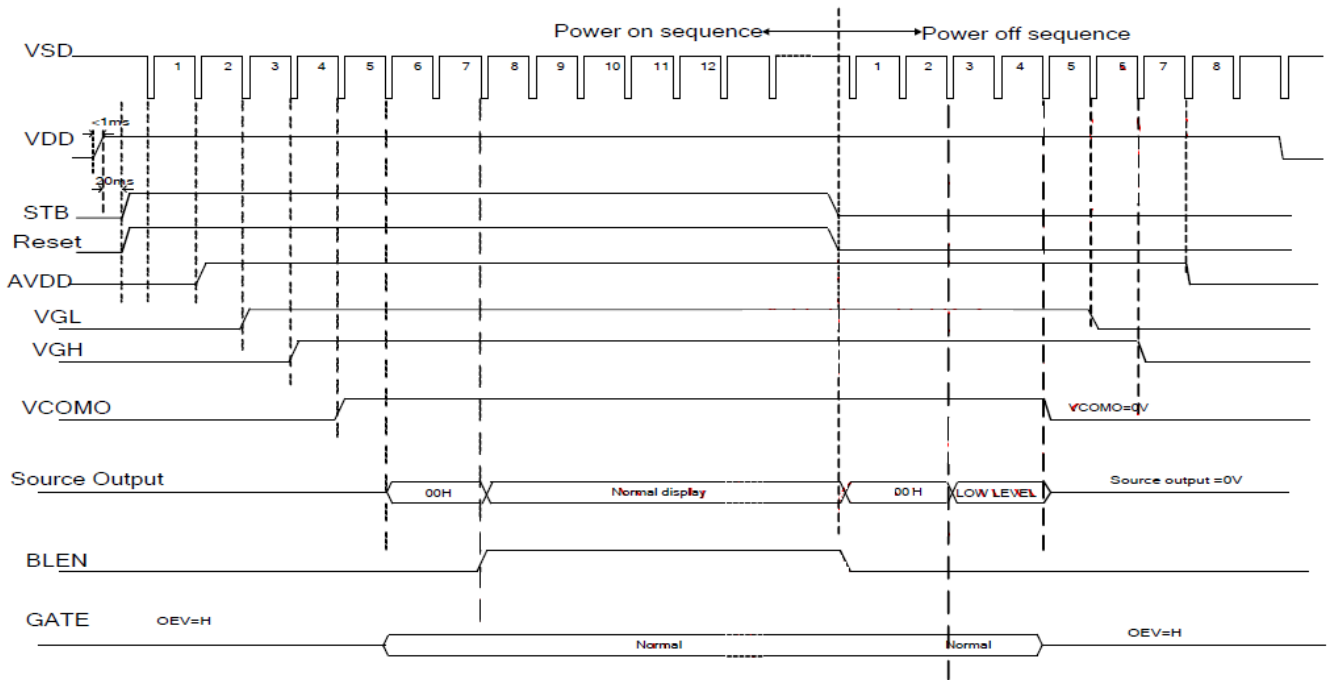

Power On/Off timing chart

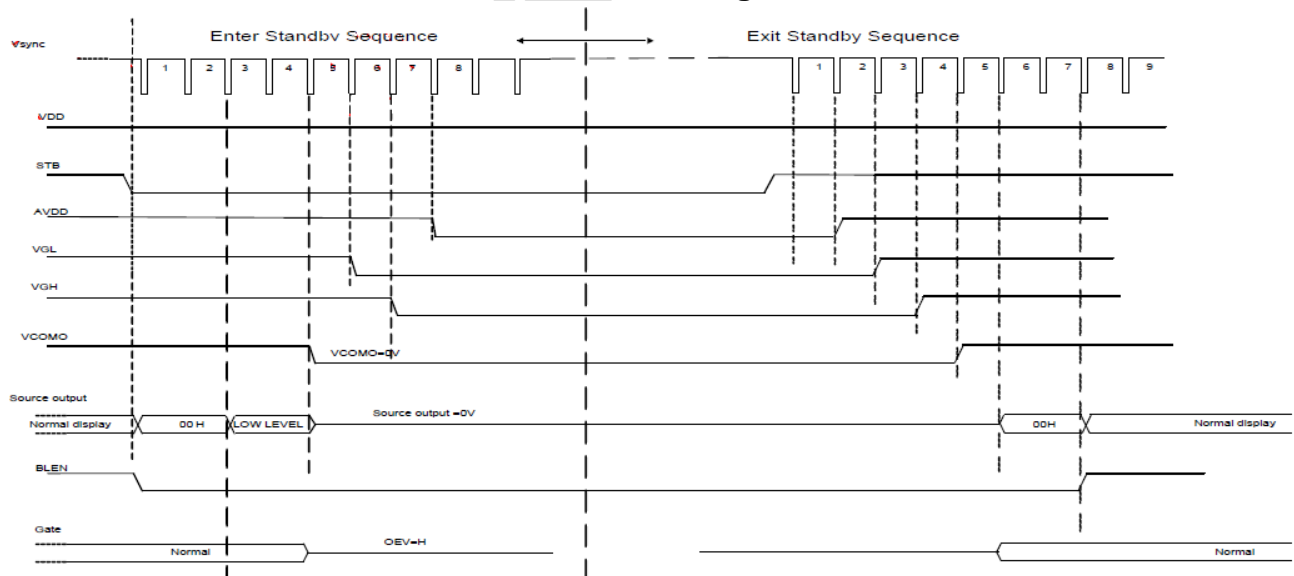

Enter and Exit Standby Mode timing chart

Note: Low level=3Fh,when NBW=L(Normally white)

Low level=00h,when NBW=H(Normally black)

8.3. Timing Characteristics

AC Electrical Characteristics

Parameter	Symbol	condition	Min.	Typ.	Max.	Unit
Clock frequency	R _x FCLK		20	-	71	MHz
Input data skew margin	T _{RSKM}	VID =400mV R _x VCM=1.2V R _x FCLK=71MHz	500	-	-	ps
Clock high time	T _{LVCH}		-	4/(7* R _x FCLK)	-	ns
Clock low time	T _{LVCL}		-	3/(7* R _x FCLK)	-	ns
PLL wake-up-time	T _{enPLL}				150	us

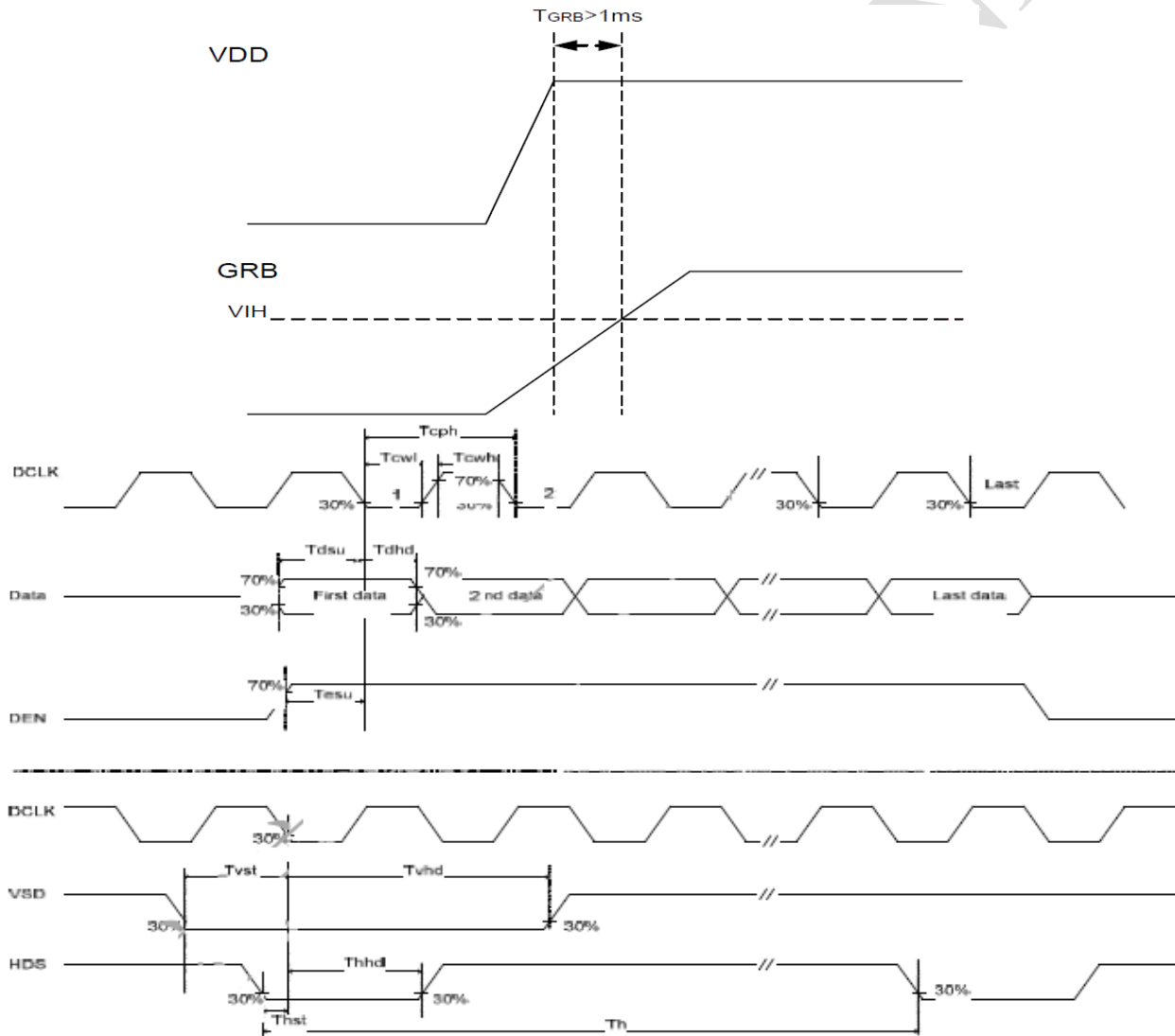

Parallel Input Clock and Data timing

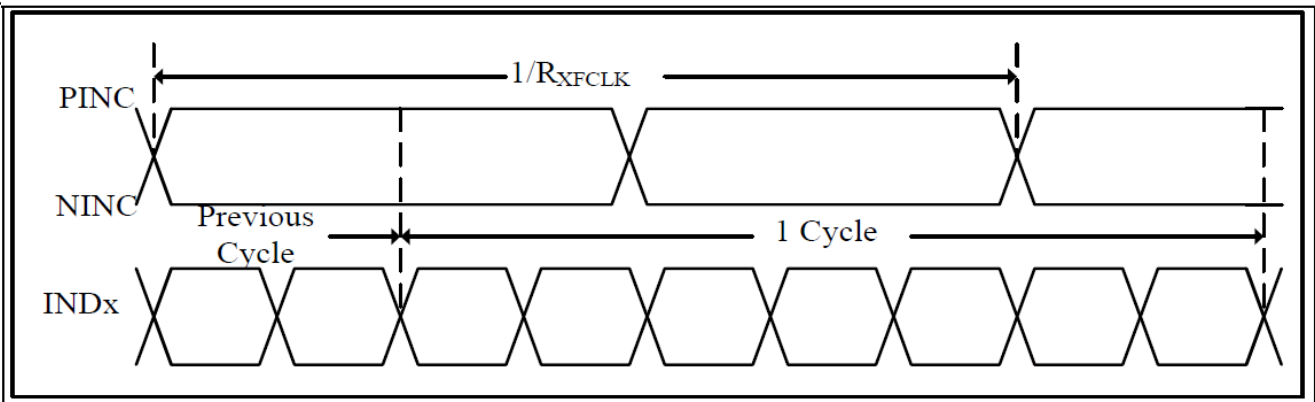

LVDS timing(1)

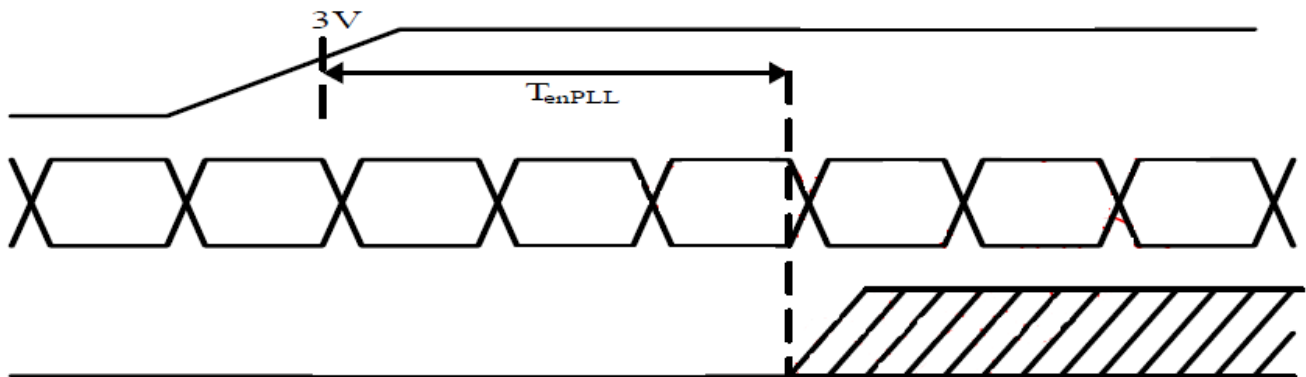

LVDS timing(2)

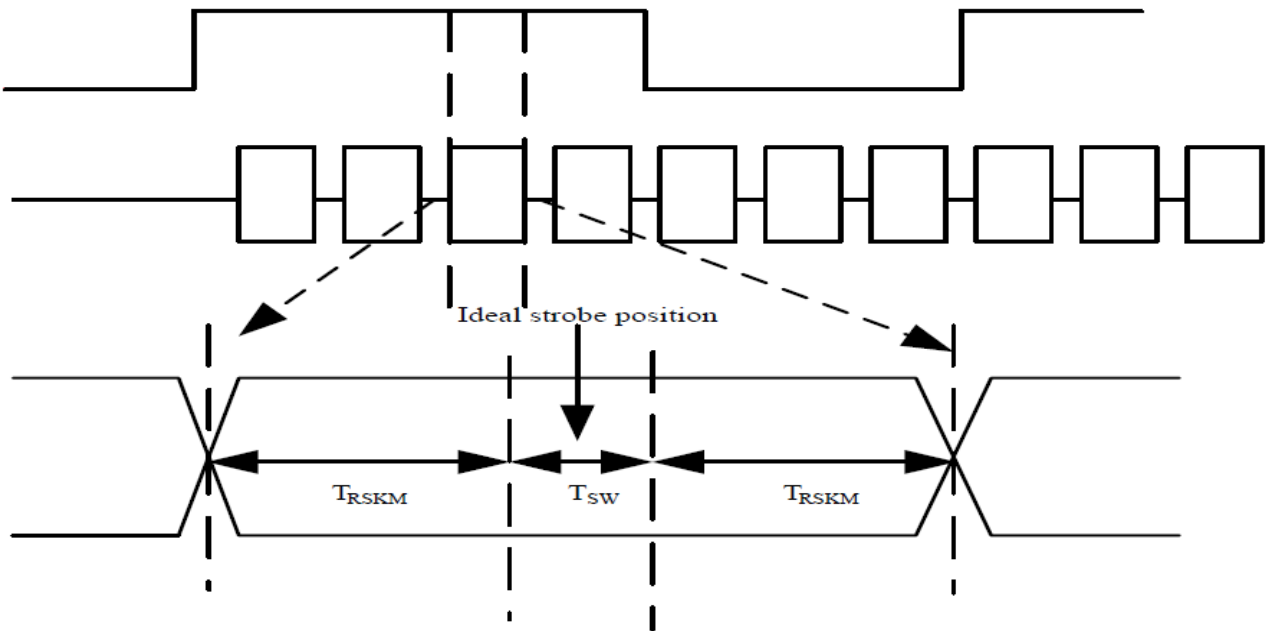

T_{SW} :Receiver strobe position
 T_{RSKM} :Receiver strobe margin

LVDS timing(3)

8.4. LVDS DC Characteristics

Parameter	Symbol	Min.	Typ.	Max.	Unit	Condition
Differential input high threshold voltage	RxVTH			+0.1V	V	RxVCM=1.2V
Differential input low threshold voltage	RxVTL	-0.1			V	
Input voltage range(single-end)	RxVIN	0		2.4	V	
Differential input common mode voltage	RxVCM	$ V_{ID} /2$		$2.4 - V_{ID} /2$	V	
Differential input voltage	$ V_{ID} $	0.2		0.6	V	
Differential input leakage current	RxVTH	-10		+10	V	
LVDS Digital Operating Current	Iddlvsd	-	40(TBD)	50	mA	Fclk=65Mhz, VDD=3.3V
LVDS Digital Standby Current	Istlvds	-	10(TBD)	50	uA	Clock & all functions are stop

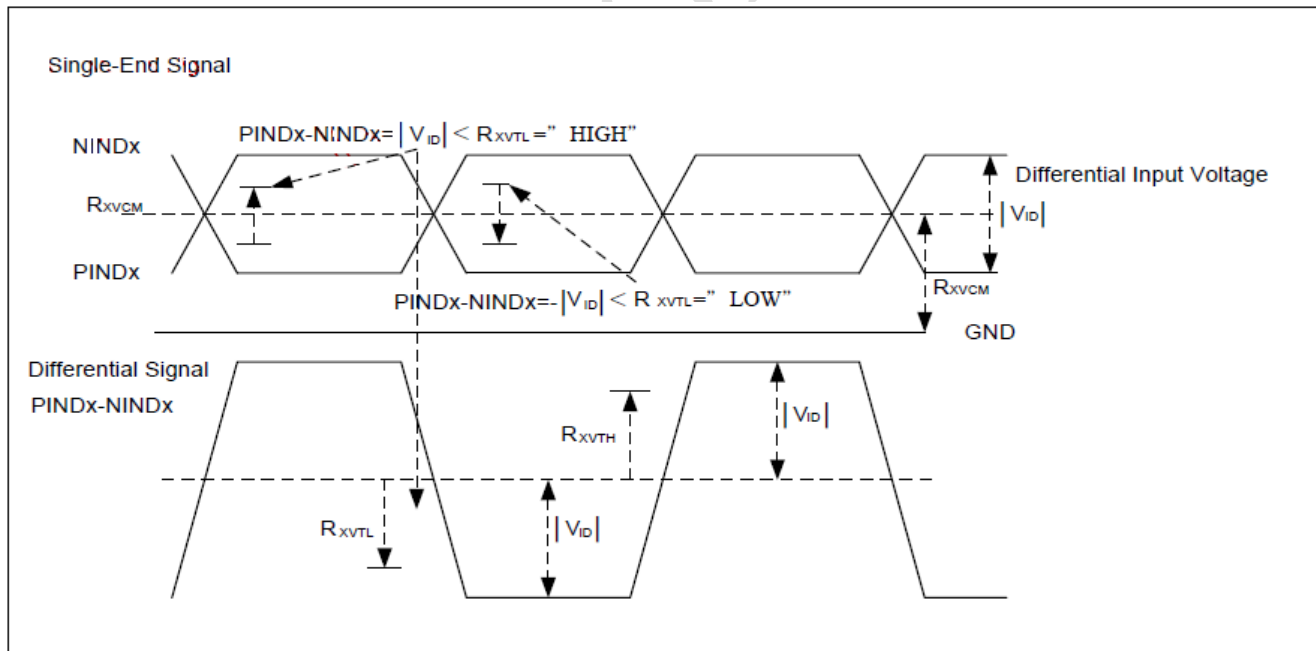

LVDS DC Characteristics

DE mode

DE mode					
Parameter	Symbol	Value			Unit
		Min.	Typ.	Max.	
DCLK frequency @Frame rate=60hz	fclk	40.8	51.2	67.2	Mhz
Horizontal display area	thd	1024			DCLK
HSYNC period time	th	1114	1344	1400	DCLK
HSYNC blanking	thb+thfp	90	320	376	DCLK
Vertical display area	tvd	600			H
VSYNC period time	tv	610	635	800	H
VSYNC blanking	tvb+tvfp	10	35	200	H

RAYSTAR OPTRON

8.5. Data Input Format

6bit LVDS input(HSD="H")

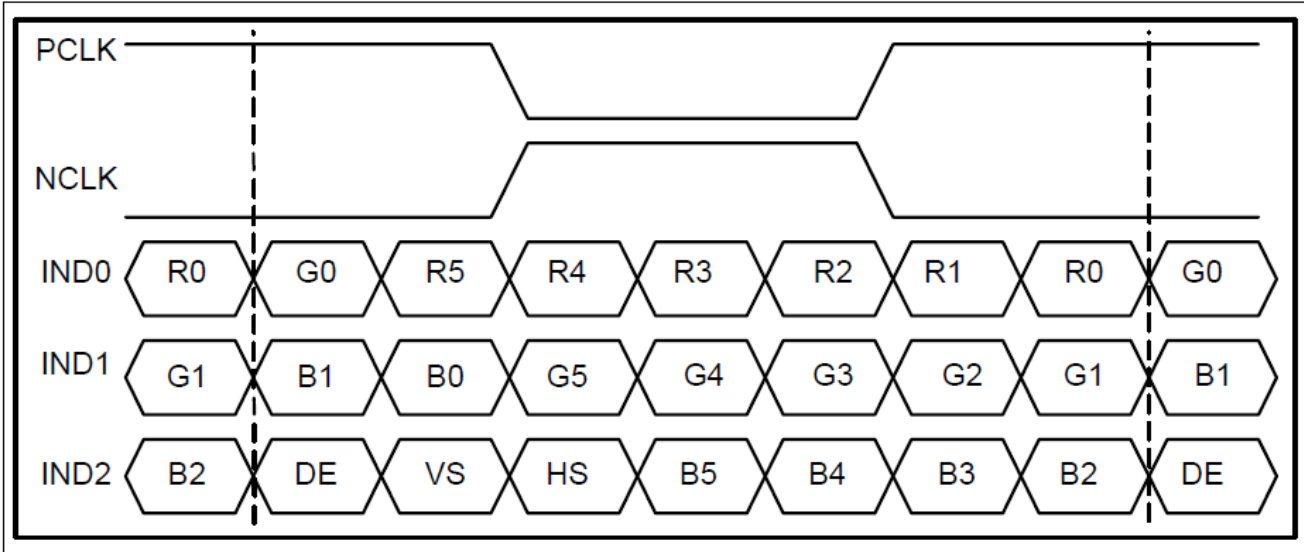

6-bit LVDS input timing chart

8bit LVDS input(HSD="L")

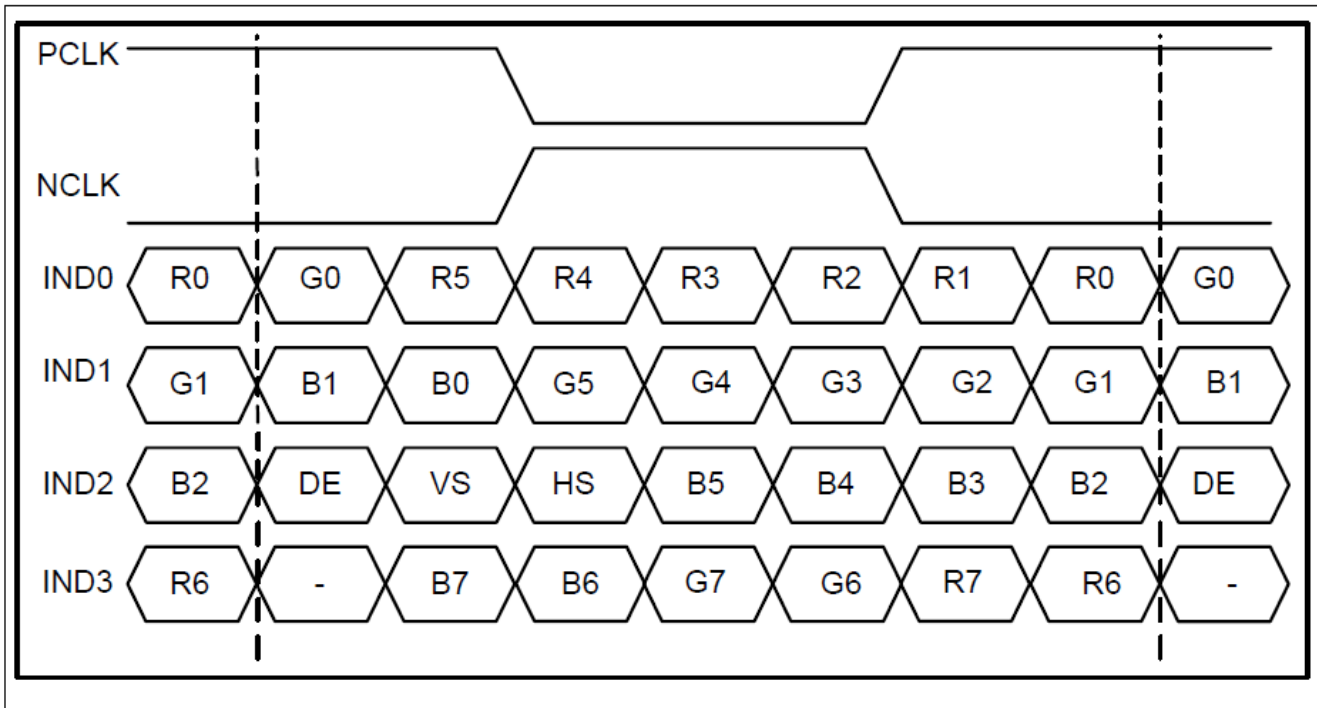

8-bit LVDS input timing chart

9. Optical Characteristics

Item	Symbol	Condition.	Min	Typ.	Max.	Unit	Remark	
Response time	Tr	$\theta=0^\circ$ 、 $\Phi=0^\circ$	-	10	20	.ms	Note 3	
	Tf		-	20	25	.ms		
Contrast ratio	CR	At optimized viewing angle	600	800	-	-	Note 4	
Color Chromaticity	White	Wx	$\theta=0^\circ$ 、 $\Phi=0^\circ$	0.252	0.302	0.352	-	Note 2,6,7
		Wy		0.274	0.324	0.374	-	
Viewing angle	Hor.	Θ_R	CR ≥ 10	80	85	-	Deg.	Note 1
		Θ_L		80	85	-		
	Ver.	Φ_T		80	85	-		
		Φ_B		80	85	-		
Brightness	-	-	700	750	-	cd/m ²	Center of display	
Uniformity	(U)	-	70	-	-	%	Note 5	

Ta=25±2°C

Note 1: Definition of viewing angle range

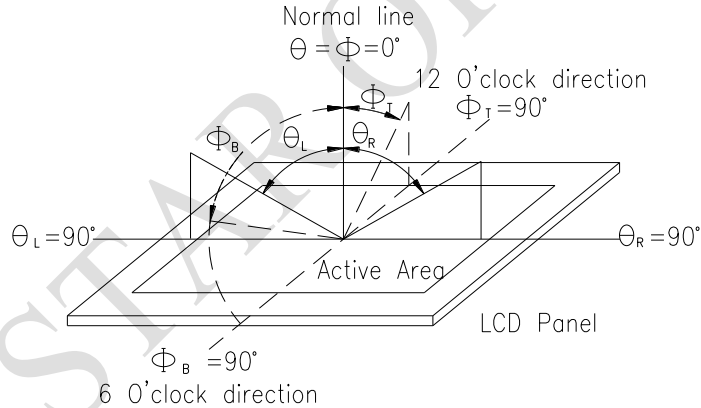

Fig. 9.1. Definition of viewing angle

Note 2: Test equipment setup:

After stabilizing and leaving the panel alone at a driven temperature for 10 minutes, the measurement should be executed. Measurement should be executed in a stable, windless, and dark room. Optical specifications are measured by Topcon BM-7 or BM-5 luminance meter 1.0° field of view at a distance of 50cm and normal direction.

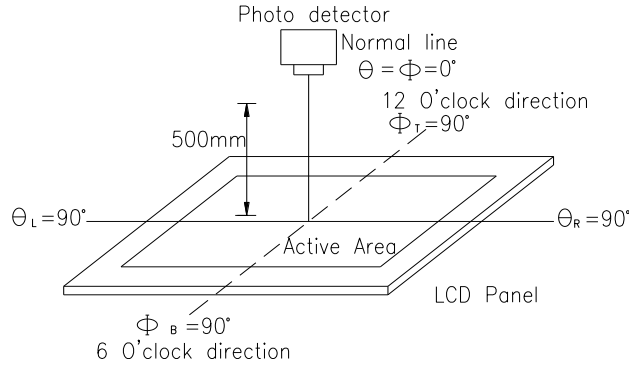
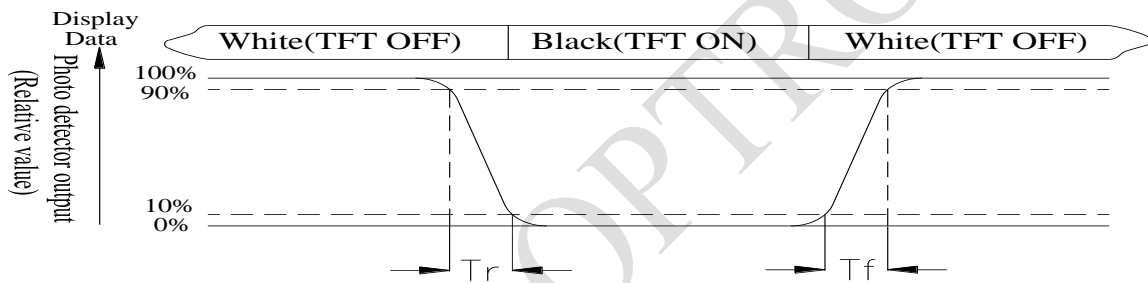

Fig. 9.2. Optical measurement system setup

Note 3: Definition of Response time:

The response time is defined as the LCD optical switching time interval between "White" state and "Black" state. Rise time, T_r , is the time between photo detector output intensity changed from 90% to 10%. And fall time, T_f , is the time between photo detector output intensity changed from 10% to 90%

Note 4: Definition of contrast ratio:

The contrast ratio is defined as the following expression.

$$\text{Contrast ratio (CR)} = \frac{\text{Luminance measured when LCD on the "White" state}}{\text{Luminance measured when LCD on the "Black" state}}$$

Note 5: Definition of Luminance Uniformity

Active area is divided into 9 measuring areas (reference the picture in below). Every measuring point is placed at the center of each measuring area.

Luminance Uniformity (U) = $L_{min}/L_{max} \times 100\%$

L = Active area length

W = Active area width

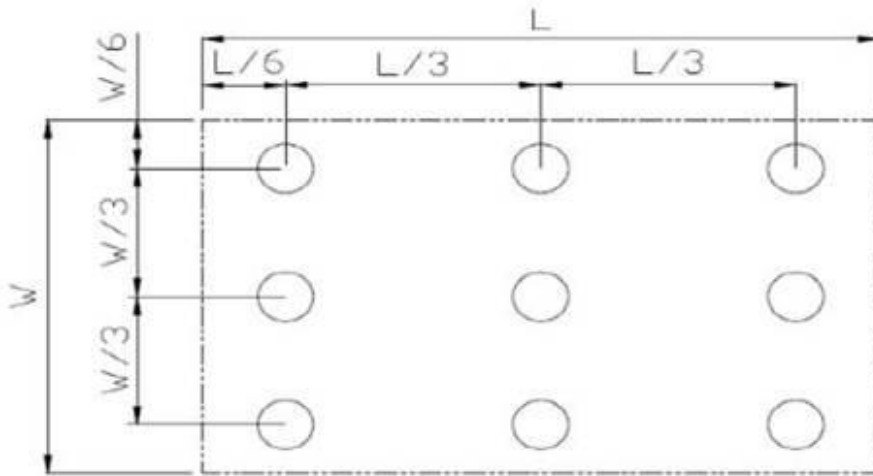

Fig 9.3. Definition of uniformity

Note 6: Definition of color chromaticity (CIE 1931)

Color coordinates measured at the center point of LCD

Note 7: Measured at the center area of the panel when all the input terminals of LCD panel are electrically opened.

10. Reliability

Content of Reliability Test (Wide temperature, $-20^{\circ}\text{C}\sim 70^{\circ}\text{C}$)

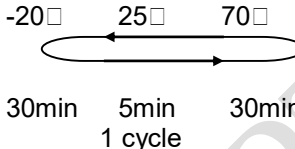
Environmental Test			
Test Item	Content of Test	Test Condition	Note
High Temperature storage	Endurance test applying the high storage temperature for a long time.	80°C 200hrs	2
Low Temperature storage	Endurance test applying the low storage temperature for a long time.	-30°C 200hrs	1,2
High Temperature Operation	Endurance test applying the electric stress (Voltage & Current) and the thermal stress to the element for a long time.	70°C 200hrs	—
Low Temperature Operation	Endurance test applying the electric stress under low temperature for a long time.	-20°C 200hrs	1
High Temperature/Humidity Operation	The module should be allowed to stand at $60^{\circ}\text{C}, 90\% \text{RH}$ max	$60^{\circ}\text{C}, 90\% \text{RH}$ 96hrs	1,2
Thermal shock resistance	The sample should be allowed stand the following 10 cycles of operation 	$-20^{\circ}\text{C}/70^{\circ}\text{C}$ 10 cycles	—
Vibration test	Endurance test applying the vibration during transportation and using.	Total fixed amplitude : 1.5mm Vibration Frequency : 10~55Hz One cycle 60 seconds to 3 directions of X,Y,Z for Each 15 minutes	3
Static electricity test	Endurance test applying the electric stress to the terminal.	VS= $\pm 600\text{V}$ (contact) , $\pm 800\text{V}$ (air), RS=330 Ω CS=150pF 10 times	—

Note1: No dew condensation to be observed.

Note2: The function test shall be conducted after 4 hours storage at the normal Temperature and humidity after remove from the test chamber.

Note3: The packing have to including into the vibration testing.

11.Touch Panel Information

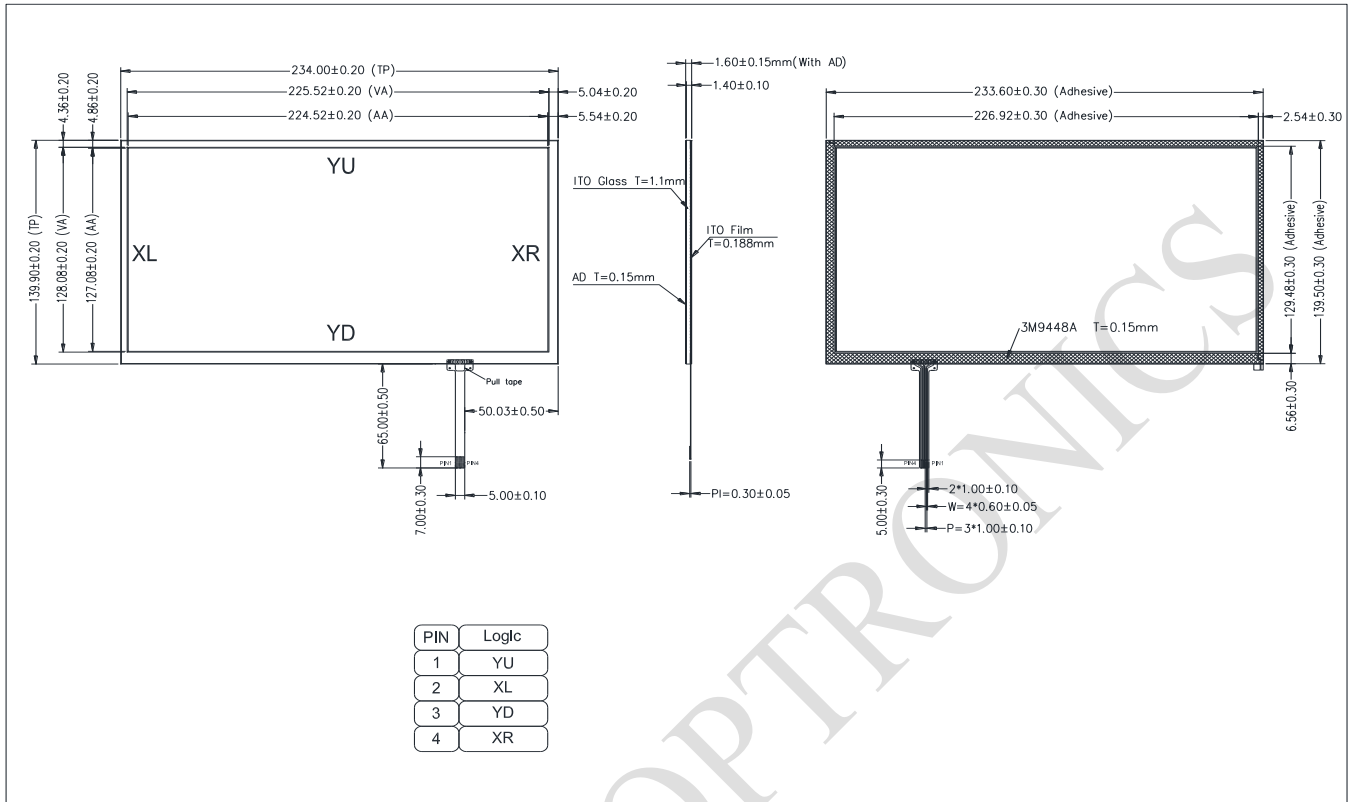

11.1. Resistance Touch Panel General Specifications

Item	Description
Driving condition	DC5V
Operating force	10~100g
Linearity max	$\leq \pm 1.5\%$
Insulating resistance	$> 20M\Omega \cdot 25V(DC)$
Light transparence	70%
Structure type	ITO Film/ITO Glass(F/G)
Surface Hardness	3H typ
Pen Hitting Durability (with the silicon rubber)	$> 1000,000$ times
X resistance	450~1100 Ω
Y resistance	100~500 Ω

LCM Sample Estimate Feedback Sheet
Module Number : _____

1 、 Panel Specification :

1. Panel Type :	<input type="checkbox"/> Pass	<input type="checkbox"/> NG , _____
2. View Direction :	<input type="checkbox"/> Pass	<input type="checkbox"/> NG , _____
3. Numbers of Dots :	<input type="checkbox"/> Pass	<input type="checkbox"/> NG , _____
4. View Area :	<input type="checkbox"/> Pass	<input type="checkbox"/> NG , _____
5. Active Area :	<input type="checkbox"/> Pass	<input type="checkbox"/> NG , _____
6. Operating Temperature :	<input type="checkbox"/> Pass	<input type="checkbox"/> NG , _____
7. Storage Temperature :	<input type="checkbox"/> Pass	<input type="checkbox"/> NG , _____
8. Others :	_____	

2 、 Mechanical Specification :

1. PCB Size :	<input type="checkbox"/> Pass	<input type="checkbox"/> NG , _____
2. Frame Size :	<input type="checkbox"/> Pass	<input type="checkbox"/> NG , _____
3. Material of Frame :	<input type="checkbox"/> Pass	<input type="checkbox"/> NG , _____
4. Connector Position :	<input type="checkbox"/> Pass	<input type="checkbox"/> NG , _____
5. Fix Hole Position :	<input type="checkbox"/> Pass	<input type="checkbox"/> NG , _____
6. Backlight Position :	<input type="checkbox"/> Pass	<input type="checkbox"/> NG , _____
7. Thickness of PCB :	<input type="checkbox"/> Pass	<input type="checkbox"/> NG , _____
8. Height of Frame to PCB :	<input type="checkbox"/> Pass	<input type="checkbox"/> NG , _____
9. Height of Module :	<input type="checkbox"/> Pass	<input type="checkbox"/> NG , _____
10. Others :	<input type="checkbox"/> Pass	<input type="checkbox"/> NG , _____

3 、 Relative Hole Size :

1. Pitch of Connector :	<input type="checkbox"/> Pass	<input type="checkbox"/> NG , _____
2. Hole size of Connector :	<input type="checkbox"/> Pass	<input type="checkbox"/> NG , _____
3. Mounting Hole size :	<input type="checkbox"/> Pass	<input type="checkbox"/> NG , _____
4. Mounting Hole Type :	<input type="checkbox"/> Pass	<input type="checkbox"/> NG , _____
5. Others :	<input type="checkbox"/> Pass	<input type="checkbox"/> NG , _____

4 、 Backlight Specification :

1. B/L Type :	<input type="checkbox"/> Pass	<input type="checkbox"/> NG , _____
2. B/L Color :	<input type="checkbox"/> Pass	<input type="checkbox"/> NG , _____
3. B/L Driving Voltage (Reference for LED Type) :	<input type="checkbox"/> Pass	<input type="checkbox"/> NG , _____
4. B/L Driving Current :	<input type="checkbox"/> Pass	<input type="checkbox"/> NG , _____
5. Brightness of B/L :	<input type="checkbox"/> Pass	<input type="checkbox"/> NG , _____
6. B/L Solder Method :	<input type="checkbox"/> Pass	<input type="checkbox"/> NG , _____
7. Others :	<input type="checkbox"/> Pass	<input type="checkbox"/> NG , _____

>> Go to page 2 <<

Module Number : _____

5、Electronic Characteristics of Module :

1.Input Voltage :	<input type="checkbox"/> Pass	<input type="checkbox"/> NG , _____
2.Supply Current :	<input type="checkbox"/> Pass	<input type="checkbox"/> NG , _____
3.Driving Voltage for LCD :	<input type="checkbox"/> Pass	<input type="checkbox"/> NG , _____
4.Contrast for LCD :	<input type="checkbox"/> Pass	<input type="checkbox"/> NG , _____
5.B/L Driving Method :	<input type="checkbox"/> Pass	<input type="checkbox"/> NG , _____
6.Negative Voltage Output :	<input type="checkbox"/> Pass	<input type="checkbox"/> NG , _____
7.Interface Function :	<input type="checkbox"/> Pass	<input type="checkbox"/> NG , _____
8.LCD Uniformity :	<input type="checkbox"/> Pass	<input type="checkbox"/> NG , _____
9.ESD test :	<input type="checkbox"/> Pass	<input type="checkbox"/> NG , _____
10.Others :	<input type="checkbox"/> Pass	<input type="checkbox"/> NG , _____

6、Summary :

Sales signature : _____

Customer Signature : _____

Date : / /