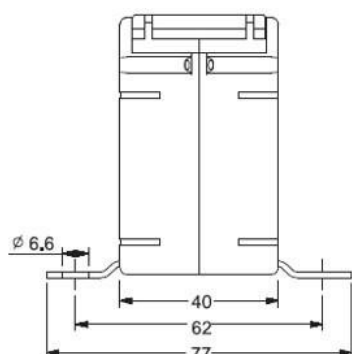
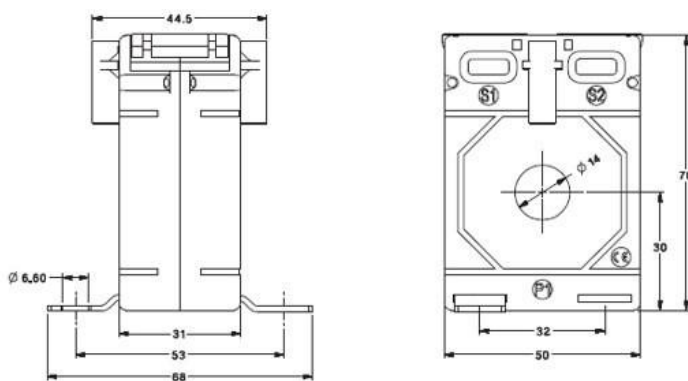

Omega XMER Current Transformers single pole, Ø 14 mm							
Series	MPN	Ratio	MPN	Ratio	VA Kl. 1	VA Kl. 0.5	VA Kl. 0.2
XMER 45-14	XM01-105011S000000	30/5A	XM01-101011S000000	30/1A	1	-	-
XMER 45-14	XM01-115011S000000	40/5A	XM01-111011S000000	40/1A	1	-	-
XMER 45-14	XM01-135031S000000	50/5A	XM01-131031S000000	50/1A	1,5	-	-
XMER 45-14	XM01-145031S000000	60/5A	XM01-141031S000000	60/1A	1,5	-	-
XMER 45-14	XM01-165051S000000	75/5A	XM01-161051S000000	75/1A	2,5	-	-
XMER 45-14	XM01-175051S000000	80/5A	XM01-171051S000000	80/1A	2,5	1	-
XMER 45-14	XM01-185071S000000	100/5A	XM01-181071S000000	100/1A	3,75	1,5	-
XMER 45-14	XM01-195071S000000	120/5A	XM01-191071S000000	120/1A	3,75	1,5	-
XMER 45-14	XM01-205071S000000	125/5A	XM01-201071S000000	125/1A	3,75	2,5	-
XMER 45-14	XM01-225081S000000	150/5A	XM01-221081S000000	150/1A	5	2,5	-
XMER 45-14	XM01-245101S000000	200/5A	XM01-241101S000000	200/1A	7,5	3,75	-
XMER 45-14	XM01-275101S000000	250/5A	XM01-271101S000000	250/1A	7,5	5	-
XMER 45-14	XM01-285111S000000	300/5A	XM01-281111S000000	300/1A	10	5	-
XMER 50-14 (30)	XM03-115011S000000	40/5A	XM03-111011S000000	40/1A	1	-	-
XMER 50-14 (30)	XM03-135031S000000	50/5A	XM03-131031S000000	50/1A	1,5	-	-
XMER 50-14 (30)	XM03-145031S000000	60/5A	XM03-141031S000000	60/1A	1,5	-	-
XMER 50-14 (30)	XM03-175031S000000	80/5A	XM03-171031S000000	80/1A	1,5	-	-
XMER 50-14 (30)	XM03-185071S000000	100/5A	XM03-181071S000000	100/1A	3,75	2,5	-
XMER 50-14 (30)	XM03-205071S000000	125/5A	XM03-201071S000000	125/1A	3,75	2,5	-
XMER 50-14 (30)	XM03-225081S000000	150/5A	XM03-221081S000000	150/1A	5	3,75	-
XMER 50-14 (30)	XM03-245081S000000	200/5A	XM03-241081S000000	200/1A	5	3,75	-
XMER 50-14 (30)	XM03-275101S000000	250/5A	XM03-271101S000000	250/1A	7,5	5	-
XMER 50-14 (30)	XM03-285101S000000	300/5A	XM03-281101S000000	300/1A	7,5	7,5	-

**XMER 45-14**

**XMER 50-14**

**Omega XMER Current Transformers single pole,  $\varnothing$  14 mm**

Series	MPN	Ratio	MPN	Ratio	VA Kl. 1	VA Kl. 0.5	VA Kl. 0.2
XMER 50-14 (50)	XM04-115011S000000	30/5A	XM04-111011S000000	30/1A	1	-	-
XMER 50-14 (50)	XM04-125011S000000	40/5A	XM04-121011S000000	40/1A	1	-	-
XMER 50-14 (50)	XM04-135031S000000	50/5A	XM04-131031S000000	50/1A	1,5	1,5	-
XMER 50-14 (50)	XM04-145031S000000	60/5A	XM04-141031S000000	60/1A	1,5	1,5	-
XMER 50-14 (50)	XM04-175081S000000	80/5A	XM04-171081S000000	80/1A	5	2,5	-
XMER 50-14 (50)	XM04-185081S000000	100/5A	XM04-181081S000000	100/1A	5	3,75	-
XMER 50-14 (50)	XM04-205081S000000	125/5A	XM04-201081S000000	125/1A	5	3,75	-
XMER 50-14 (50)	XM04-225101S000000	150/5A	XM04-221101S000000	150/1A	7,5	5	-
XMER 50-14 (50)	XM04-245111S000000	200/5A	XM04-241111S000000	200/1A	10	7,5	-
XMER 50-14 (50)	XM04-275111S000000	250/5A	XM04-271111S000000	250/1A	10	10	-
XMER 50-14 (50)	XM04-285111S000000	300/5A	XM04-281111S000000	300/1A	10	10	-

**Omega XMER Current Transformers single pole,  $\varnothing$  20mm, Busbar 20x10mm**

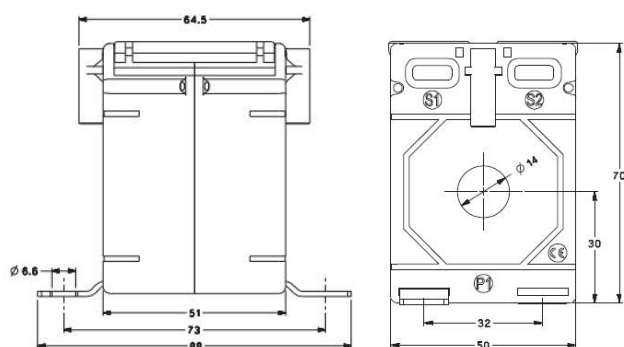
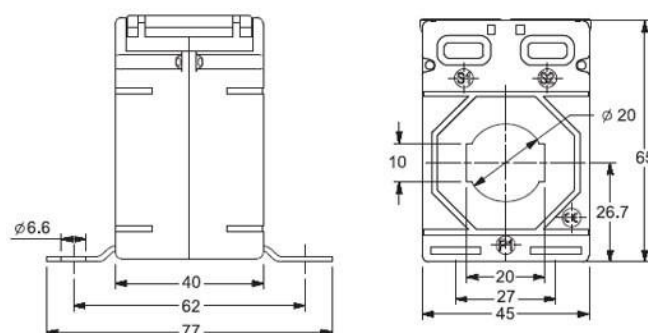
Series	MPN	Ratio	MPN	Ratio	VA Kl. 1	VA Kl. 0.5	VA Kl. 0.2
XMER 45-21	XM02-135031S000000	50/5A	XM02-131031S000000	50/1A	1,5	-	-
XMER 45-21	XM02-145031S000000	60/5A	XM02-141031S000000	60/1A	1,5	-	-
XMER 45-21	XM02-175051S000000	80/5A	XM02-171051S000000	80/1A	2,5	1	-
XMER 45-21	XM02-185071S000000	100/5A	XM02-181071S000000	100/1A	3,75	1,5	-
XMER 45-21	XM02-195071S000000	120/5A	XM02-191071S000000	120/1A	3,75	2,5	-
XMER 45-21	XM02-205071S000000	125/5A	XM02-201071S000000	125/1A	3,75	2,5	-

XMER 45-21	XM02-225081S000000	150/5A	XM02-221081S000000	150/1A	5	2,5	-
XMER 45-21	XM02-245081S000000	200/5A	XM02-241081S000000	200/1A	5	3,75	-
XMER 45-21	XM02-275081S000000	250/5A	XM02-271081S000000	250/1A	5	5	-
XMER 45-21	XM02-285081S000000	300/5A	XM02-281081S000000	300/1A	5	5	-
XMER 45-21	XM02-315081S000000	400/5A	XM02-311081S000000	400/1A	5	5	-

**XMER 50-14 (50)**

**XMER 45-21**

**Omega XMER Current Transformers single pole,  $\varnothing$  21mm, Busbar 20x10mm**

Series	MPN	Ratio	MPN	Ratio	VA Kl. 1	VA Kl. 0.5	VA Kl. 0.2
XMER 50-21 (30)	XM05-135011S000000	50/5A	XM05-131011S000000	50/1A	1	-	-
XMER 50-21 (30)	XM05-145011S000000	60/5A	XM05-141011S000000	60/1A	1	-	-
XMER 50-21 (30)	XM05-175051S000000	80/5A	XM05-171051S000000	80/1A	2,5	1	-
XMER 50-21 (30)	XM05-185051S000000	100/5A	XM05-181051S000000	100/1A	2,5	1,5	-
XMER 50-21 (30)	XM05-195051S000000	120/5A	XM05-191051S000000	120/1A	2,5	2,5	-
XMER 50-21 (30)	XM05-205071S000000	125/5A	XM05-201071S000000	125/1A	3,75	2,5	-
XMER 50-21 (30)	XM05-225081S000000	150/5A	XM05-221081S000000	150/1A	5	2,5	-
XMER 50-21 (30)	XM05-245081S000000	200/5A	XM05-241081S000000	200/1A	5	3,75	-
XMER 50-21 (30)	XM05-275081S000000	250/5A	XM05-271081S000000	250/1A	5	5	-
XMER 50-21 (30)	XM05-285101S000000	300/5A	XM05-281101S000000	300/1A	7,5	5	-
XMER 50-21 (30)	XM05-315101S000000	400/5A	XM05-311101S000000	400/1A	7,5	5	-
XMER 50-21 (30)	XM05-325091S000000	500/5A	-	-	6,25	-	-
XMER 50-21 (30)	XM05-335101S000000	600/5A	-	-	7,5	-	-

### Omega XMER Current Transformers single pole, $\varnothing$ 20mm, Busbar 20x10mm

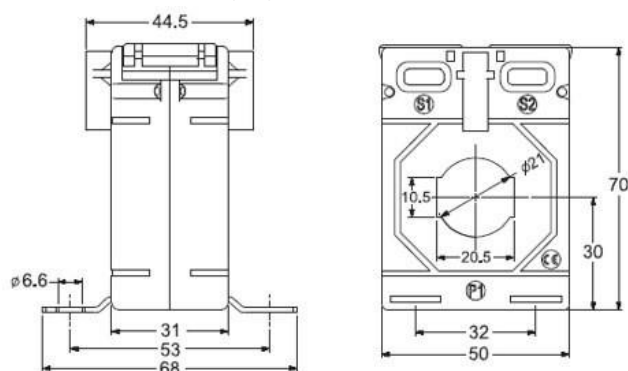
Series	MPN	Ratio	MPN	Ratio	VA Kl. 1	VA Kl. 0.5	VA Kl. 0.2
XMER 50-21 (50)	XM06-145051S000000	60/5A	XM06-141051S000000	60/1A	2,5	1	-
XMER 50-21 (50)	XM06-175071S000000	80/5A	XM06-171071S000000	80/1A	5	2,5	-
XMER 50-21 (50)	XM06-185071S000000	100/5A	XM06-181071S000000	100/1A	5	2,5	-
XMER 50-21 (50)	XM06-205071S000000	125/5A	XM06-201071S000000	125/1A	5	5	-
XMER 50-21 (50)	XM06-225111S000000	150/5A	XM06-221111S000000	150/1A	10	5	-
XMER 50-21 (50)	XM06-245111S000000	200/5A	XM06-241111S000000	200/1A	10	7,5	-
XMER 50-21 (50)	XM06-275115S000000	250/5A	XM06-271115S000000	250/1A	10	7,5	-
XMER 50-21 (50)	XM06-285121S000000	300/5A	XM06-281121S000000	300/1A	12,5	7,5	-
XMER 50-21 (50)	XM06-315131S000000	400/5A	XM06-311131S000000	400/1A	15	10	-

#### XMER 50-21 (30)



#### XMER 50-21 (50)

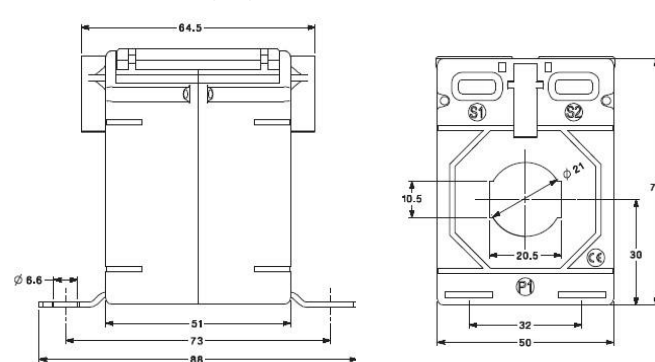

### Omega XMER Current Transformers single pole, $\varnothing$ 26mm, Busbar 30x10, 25x15mm

Series	MPN	Ratio	MPN	Ratio	VA Kl. 1	VA Kl. 0.5	VA Kl. 0.2
XMER 50-30 (30)	XM07-175031S000000	80/5A	XM07-171031S000000	80/1A	1,5	-	-
XMER 50-30 (30)	XM07-185051S000000	100/5A	XM07-181051S000000	100/1A	2,5	1	-
XMER 50-30 (30)	XM07-205051S000000	125/5A	XM07-201051S000000	125/1A	2,5	1	-
XMER 50-30 (30)	XM07-225071S000000	150/5A	XM07-221071S000000	150/1A	5	2,5	-
XMER 50-30 (30)	XM07-245081S000000	200/5A	XM07-241081S000000	200/1A	5	2,5	-
XMER 50-30 (30)	XM07-275081S000000	250/5A	XM07-271081S000000	250/1A	5	3,75	-
XMER 50-30 (30)	XM07-285081S000000	300/5A	XM07-281081S000000	300/1A	5	3,75	-
XMER 50-30 (30)	XM07-315091S000000	400/5A	XM07-311091S000000	400/1A	6,25	5	-

XMER 50-30 (30)	XM07-325091S000000	500/5A	XM07-321091S000000	500/1A	6,25	5	-
XMER 50-30 (30)	XM07-335101S000000	600/5A	XM07-331101S000000	600/1A	7,5	5	-
XMER 50-30 (50)	XM08-175051S000000	80/5A	XM08-175051S000000	80/1A	2,5	-	-
XMER 50-30 (50)	XM08-185081S000000	100/5A	XM08-185081S000000	100/1A	5	2,5	-
XMER 50-30 (50)	XM08-205081S000000	125/5A	XM08-205081S000000	125/1A	5	2,5	-
XMER 50-30 (50)	XM08-225081S000000	150/5A	XM08-225081S000000	150/1A	5	5	-
XMER 50-30 (50)	XM08-245101S000000	200/5A	XM08-245101S000000	200/1A	7,5	5	-
XMER 50-30 (50)	XM008275111S000000	250/5A	XM008275111S000000	250/1A	10	5	-
XMER 50-30 (50)	XM08-285111S000000	300/5A	XM08-285111S000000	300/1A	10	5	-
XMER 50-30 (50)	XM08-31521S0000000	400/5A	XM08-31521S0000000	400/1A	12,5	10	-
XMER 50-30 (50)	XM08-325121S000000	500/5A	XM08-325121S000000	500/1A	12,5	10	-
XMER 50-30 (50)	XM08-335131S000000	600/5A	XM08-335131S000000	600/1A	15	10	-

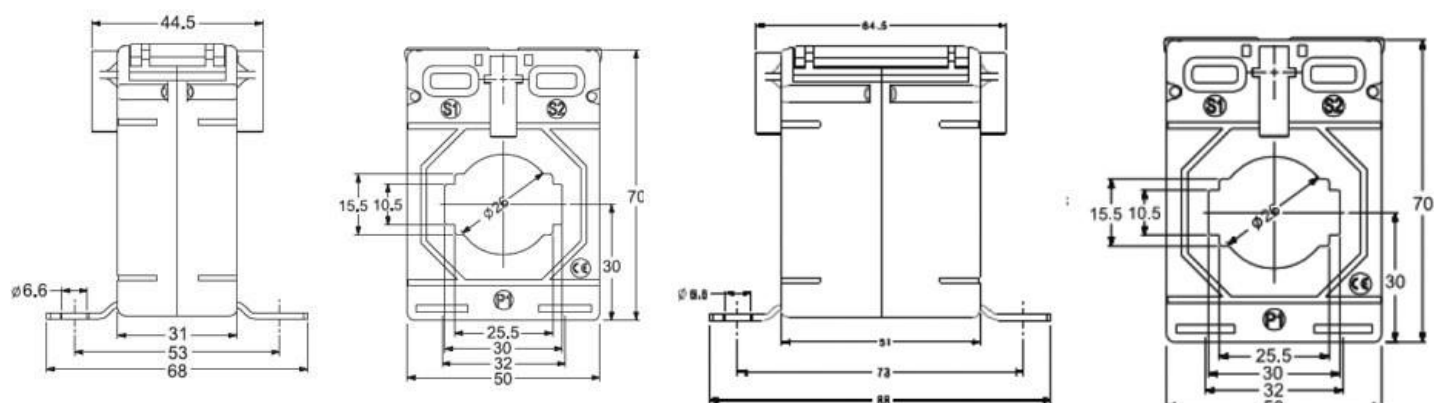
**XMER 50-30 (30)**
**XMER 50-30 (50)**

**Omega XMER Current Transformers single pole, Ø 30,5mm, Busbar 30x10, 25x25 & 20x20mm (H&V)**

Series	MPN	Ratio	MPN	Ratio	VA Kl. 1	VA Kl. 0.5	VA Kl. 0.2
XMER 62-30 (40)	XM11-185051S000000	100/5A	XM11-181051S000000	100/1A	2,5	1,5	1
XMER 62-30 (40)	XM11-225081S000000	150/5A	XM11-221081S000000	150/1A	5	3,75	1,5
XMER 62-30 (40)	XM11-245101S000000	200/5A	XM11-241101S000000	200/1A	7,5	5	2,5
XMER 62-30 (40)	XM11-275111S000000	250/5A	XM11-271111S000000	250/1A	10	5	3,75
XMER 62-30 (40)	XM11-285111S000000	300/5A	XM11-281111S000000	300/1A	10	5	3,75
XMER 62-30 (40)	XM11-315121S000000	400/5A	XM11-311121S000000	400/1A	12,5	7,5	5
XMER 62-30 (40)	XM11-325121S000000	500/5A	XM11-321121S000000	500/1A	12,5	10	7,5

XMER 62-30 (40)	XM11-335131S000000	600/5A	XM11-331131S000000	600/1A	15	15	7,5
XMER 62-30 (40)	XM11-365131S000000	750/5A	XM11-361131S000000	750/1A	15	15	10
XMER 62-30 (40)	XM11-375131S000000	800/5A	XM11-371131S000000	800/1A	15	15	10

**Omega XMER Current Transformers single pole, Ø 22,5mm**

Series	MPN	Ratio	MPN	Ratio	VA Kl. 1	VA Kl. 0.5	VA Kl. 0.2
XMER 62R	XM09-135021S000000	50/5A	XM09-131021S000000	50/1A	1,5	-	-
XMER 62R	XM09-145051S000000	60/5A	XM09-141051S000000	60/1A	2,5	-	-
XMER 62R	XM09-175051S000000	80/5A	XM09-171051S000000	80/1A	2,5	-	-
XMER 62R	XM09-185081S000000	100/5A	XM09-181081S000000	100/1A	5	2,5	-
XMER 62R	XM09-205081S000000	125/5A	XM09-201081S000000	125/1A	5	3,75	-
XMER 62R	XM09-225101S000000	150/5A	XM09-221101S000000	150/1A	7,5	5	-
XMER 62R	XM09-245111S000000	200/5A	XM09-241111S000000	200/1A	10	7,5	-
XMER 62R	XM09-275131S000000	250/5A	XM09-271131S000000	250/1A	15	10	-
XMER 62R	XM09-285131S000000	300/5A	XM09-281131S000000	300/1A	15	10	-
XMER 62R	XM09-315131S000000	400/5A	XM09-311131S000000	400/1A	15	15	-
XMER 62R	XM09-325131S000000	500/5A	XM09-321131S000000	500/1A	15	15	-
XMER 62R	XM09-335131S000000	600/5A	XM09-331131S000000	600/1A	15	15	-

**XMER 62-30 (40)**

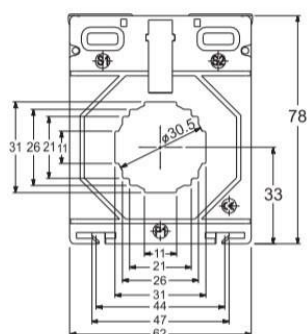
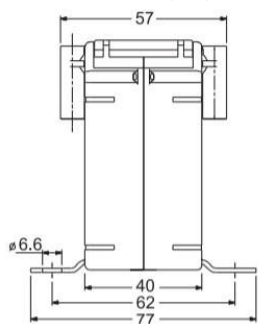

**XMER 62-R**

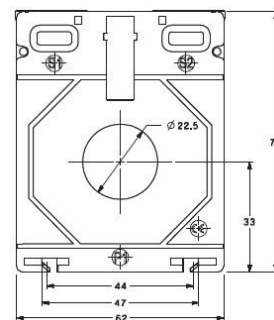
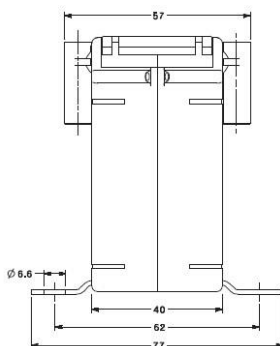

**Omega XMER Current Transformers single pole, Ø 28mm, Busbar 30x10mm – horizontal & vertical**

Series	MPN	Ratio	MPN	Ratio	VA Kl. 1	VA Kl. 0.5	VA Kl. 0.2
XMER 62-30 (50)	XM12-185081S000000	100/5A	XM12-181081S000000	100/1A	5	5	1,25
XMER 62-30 (50)	XM12-205081S000000	125/5A	XM12-201081S000000	125/1A	5	5	1,25
XMER 62-30 (50)	XM12-225101S000000	150/5A	XM12-221101S000000	150/1A	7,5	5	1,5

XMER 62-30 (50)	XM12-245131S000000	200/5A	XM12-241131S000000	200/1A	15	10	2
XMER 62-30 (50)	XM12-275131S000000	250/5A	XM12-271131S000000	250/1A	15	15	5
XMER 62-30 (50)	XM12-285131S000000	300/5A	XM12-281131S000000	300/1A	15	15	5
XMER 62-30 (50)	XM12-315151S000000	400/5A	XM12-311151S000000	400/1A	30	15	6,25
XMER 62-30 (50)	XM12-325151S000000	500/5A	XM12-321151S000000	500/1A	30	15	7,5
XMER 62-30 (50)	XM12-335151S000000	600/5A	XM12-331151S000000	600/1A	30	20	10
XMER 62-30 (50)	XM12-365151S000000	750/5A	XM12-361151S000000	750/1A	30	20	10
XMER 62-30 (50)	XM12-375151S000000	800/5A	XM12-371151S000000	800/1A	30	20	10

**Omega XMER Current Transformers single pole, Ø 31mm, Busbar 40x10, 30x20 & 15x30mm**

Series	MPN	Ratio	MPN	Ratio	VA Kl. 1	VA Kl. 0.5	VA Kl. 0.2
XMER 62-40	XM13-185011S000000	100/5A	XM13-181011S000000	100/1A	1	-	-
XMER 62-40	XM13-205031S000000	125/5A	XM13-201031S000000	125/1A	1,5	-	-
XMER 62-40	XM13-225051S000000	150/5A	XM13-221051S000000	150/1A	2,5	-	-
XMER 62-40	XM13-245071S000000	200/5A	XM13-241071S000000	200/1A	3,75	1,5	-
XMER 62-40	XM13-275081S000000	250/5A	XM13-271081S000000	250/1A	5	2,5	1,5
XMER 62-40	XM13-285081S000000	300/5A	XM13-281081S000000	300/1A	5	5	1,5
XMER 62-40	XM13-315081S000000	400/5A	XM13-311081S000000	400/1A	5	5	2,5
XMER 62-40	XM13-325101S000000	500/5A	XM13-321101S000000	500/1A	7,5	5	5
XMER 62-40	XM13-335111S000000	600/5A	XM13-331111S000000	600/1A	10	7,5	7,5
XMER 62-40	XM13-365111S000000	750/5A	XM13-361111S000000	750/1A	10	10	10
XMER 62-40	XM13-375111S000000	800/5A	XM13-371111S000000	800/1A	10	10	10

**XMER 62-30 (50)**

**XMER 62-40**

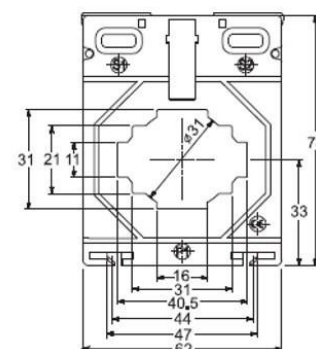
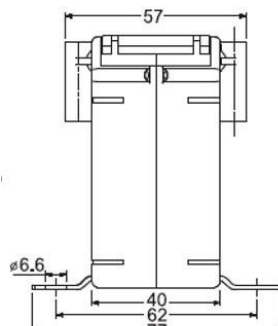
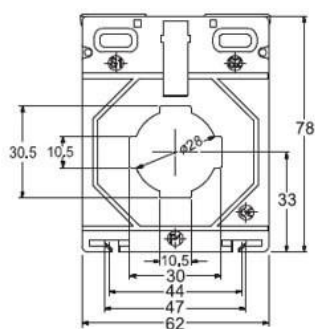
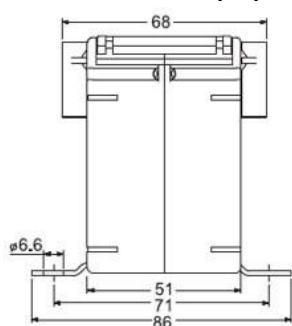

<b>Omega XMER Current Transformers single pole, Ø 26mm, Busbar 30x15, 20x20 &amp; 15x30mm</b>							
Series	MPN	Ratio	MPN	Ratio	VA Kl. 1	VA Kl. 0.5	VA Kl. 0.2
XMER 74-30	XM15-185081S000000	100/5A	XM15-185081S000000	100/1A	5	2,5	1,5
XMER 74-30	XM16-205081S000000	125/5A	XM16-205081S000000	125/1A	5	2,5	1,5
XMER 74-30	XM16-225101S000000	150/5A	XM16-225101S000000	150/1A	7,5	5	1,5
XMER 74-30	XM16-245131S000000	200/5A	XM16-245131S000000	200/1A	15	10	2,5
XMER 74-30	XM16-275131S000000	250/5A	XM16-275131S000000	250/1A	15	10	2,5
XMER 74-30	XM16-285131S000000	300/5A	XM16-285131S000000	300/1A	15	10	5
XMER 74-30	XM16-315141S000000	400/5A	XM16-315141S000000	400/1A	20	15	7,5
XMER 74-30	XM16-325141S000000	500/5A	XM16-325141S000000	500/1A	20	15	10
XMER 74-30	XM16-335141S000000	600/5A	XM16-335141S000000	600/1A	20	15	15
XMER 74-30	XM16-365151S000000	750/5A	XM16-365151S000000	750/1A	30	20	20
XMER 74-30	XM16-375151S000000	800/5A	XM16-375151S000000	800/1A	30	20	20
<b>Omega XMER Current Transformers single pole, Ø 35mm, Busbar 40x12.5, 30x30 &amp; 12,5x40mm</b>							
Series	MPN	Ratio	MPN	Ratio	VA Kl. 1	VA Kl. 0.5	VA Kl. 0.2
XMER 74-40	XM16-185051S000000	100/5A	XM16-185051S000000	100/1A	2,5	1,5	-
XMER 74-40	XM16-205051S000000	125/5A	XM16-205051S000000	125/1A	2,5	1,5	-
XMER 74-40	XM16-225071S000000	150/5A	XM16-225071S000000	150/1A	3,75	2,5	-
XMER 74-40	XM16-245081S000000	200/5A	XM16-245081S000000	200/1A	5	3,75	2,5
XMER 74-40	XM16-275101S000000	250/5A	XM16-275101S000000	250/1A	7,5	5	2,5
XMER 74-40	XM16-285101S000000	300/5A	XM16-285101S000000	300/1A	7,5	5	2,5
XMER 74-40	XM16-315121S000000	400/5A	XM16-315121S000000	400/1A	12,5	7,5	5
XMER 74-40	XM16-325131S000000	500/5A	XM16-325131S000000	500/1A	15	10	7,5
XMER 74-40	XM16-335141S000000	600/5A	XM16-335141S000000	600/1A	20	15	10
XMER 74-40	XM16-365141S000000	750/5A	XM16-365141S000000	750/1A	20	15	10

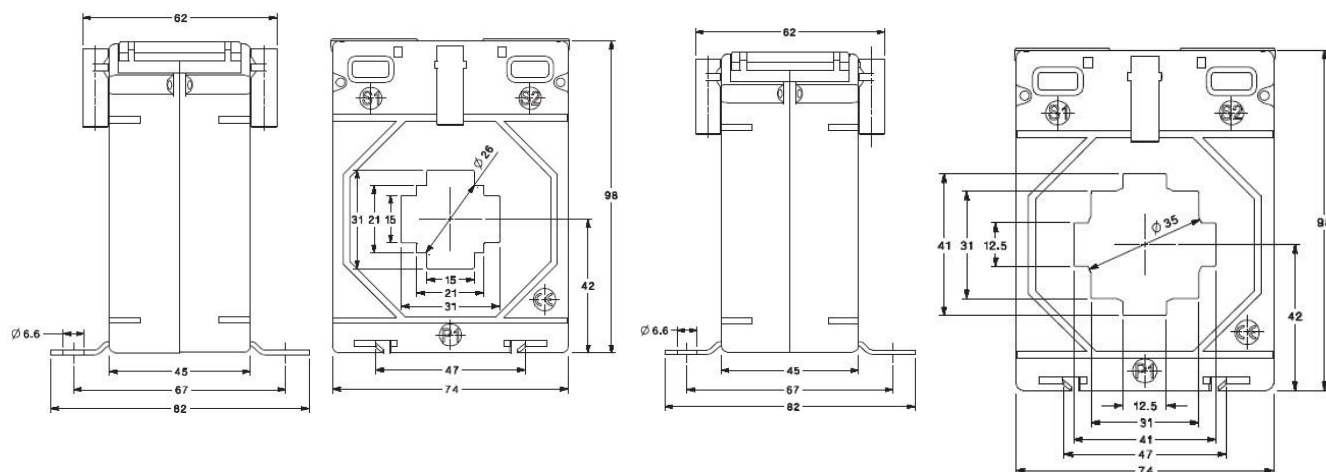

XMER 74-40	XM16-375141S000000	800/5A	XM16-371141S000000	800/1A	20	15	15
XMER 74-40	XM16-395141S000000	1000/5A	XM16-391141S000000	1000/1A	20	15	15

**XMER 74-30**
**XMER 74-40**

**Omega XMER Current Transformers single pole, Ø 41mm, Busbar 50x12.5, 40x20 & 30x30mm**

Series	MPN	Ratio	MPN	Ratio	VA Kl. 1	VA Kl. 0.5	VA Kl. 0.2
XMER 74-50	XM17-185031S000000	100/5A	XM17-181031S000000	100/1A	1,5	-	-
XMER 74-50	XM17-205031S000000	125/5A	XM17-201031S000000	125/1A	1,5	-	-
XMER 74-50	XM17-225051S000000	150/5A	XM17-221051S000000	150/1A	2,5	-	-
XMER 74-50	XM17-245071S000000	200/5A	XM17-241071S000000	200/1A	3,75	-	-
XMER 74-50	XM17-275081S000000	250/5A	XM17-271081S000000	250/1A	5	2,5	-
XMER 74-50	XM17-285101S000000	300/5A	XM17-281101S000000	300/1A	7,5	5	-
XMER 74-50	XM17-315101S000000	400/5A	XM17-311101S000000	400/1A	7,5	5	2,5
XMER 74-50	XM17-325111S000000	500/5A	XM17-321111S000000	500/1A	10	7,5	5
XMER 74-50	XM17-335121S000000	600/5A	XM17-331121S000000	600/1A	12,5	10	7,5
XMER 74-50	XM17-365131S000000	750/5A	XM17-361131S000000	750/1A	15	12,5	10
XMER 74-50	XM17-375131S000000	800/5A	XM17-371131S000000	800/1A	15	12,5	10
XMER 74-50	XM17-395131S000000	1000/5A	XM17-391131S000000	1000/1A	15	12,5	10

**Omega XMER Current Transformers single pole, Ø 46mm, Busbar 50x12,5 & 40x30mm**

Series	MPN	Ratio	MPN	Ratio	VA Kl. 1	VA Kl. 0.5	VA Kl. 0.2
XMER 86-50	XM19-245101S000000	200/5A	XM19-241101S000000	200/1A	7,5	5	-
XMER 86-50	XM19-275111S000000	250/5A	XM19-271111S000000	250/1A	10	7,5	-

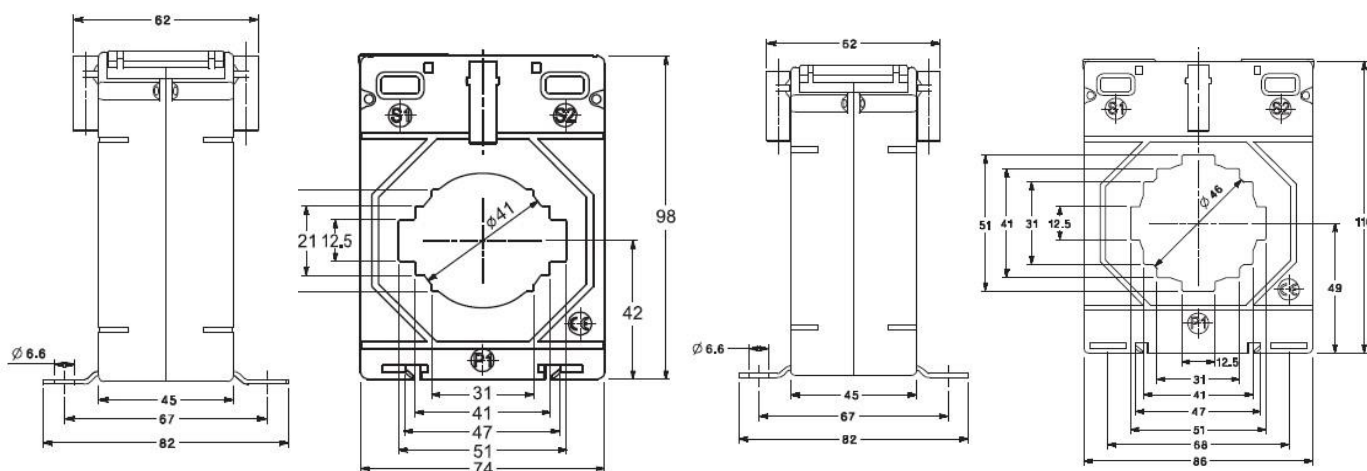
XMER 86-50	XM19-285111S000000	300/5A	XM19-281111S000000	300/1A	10	7,5	1,5
XMER 86-50	XM19-315131S000000	400/5A	XM19-311131S000000	400/1A	15	15	2,5
XMER 86-50	XM19-325141S000000	500/5A	XM19-321141S000000	500/1A	20	15	5
XMER 86-50	XM19-335141S000000	600/5A	XM19-331141S000000	600/1A	20	15	7,5
XMER 86-50	XM19-365141S000000	750/5A	XM19-361141S000000	750/1A	20	15	10
XMER 86-50	XM19-375151S000000	800/5A	XM19-371151S000000	800/1A	30	20	12,5
XMER 86-50	XM19-395151S000000	1000/5A	XM19-391151S000000	1000/1A	30	30	20
XMER 86-50	XM19-405151S000000	1200/5A	XM19-401151S000000	1200/1A	30	30	20
XMER 86-50	XM19-415151S000000	1250/5A	XM19-411151S000000	1250/1A	30	30	20

**XMER 74-50**
**XMER 86-50**

**Omega XMER Current Transformers single pole, Ø 51 & 61x12,5 & 31x51, 30x40, 21x51 mm**

Series	MPN	Ratio	MPN	Ratio	VA Kl. 1	VA Kl. 0.5	VA Kl. 0.2
XMER 86-60	XM20-275051S000000	250/5A	XM20-271051S000000	250/1A	2,5	2,5	-
XMER 86-60	XM20-285081S000000	300/5A	XM20-281081S000000	300/1A	5	5	1,5
XMER 86-60	XM20-315111S000000	400/5A	XM20-311111S000000	400/1A	10	10	2,5
XMER 86-60	XM20-325111S000000	500/5A	XM20-321111S000000	500/1A	10	10	3,75
XMER 86-60	XM20-335131S000000	600/5A	XM20-331131S000000	600/1A	15	15	5
XMER 86-60	XM20-365141S000000	750/5A	XM20-361141S000000	750/1A	20	15	10
XMER 86-60	XM20-375141S000000	800/5A	XM20-371141S000000	800/1A	20	20	12,5
XMER 86-60	XM20-395141S000000	1000/5A	XM20-391141S000000	1000/1A	20	20	15
XMER 86-60	XM20-405141S000000	1200/5A	XM20-401141S000000	1200/1A	20	20	15

XMER 86-60	XM20-415141S000000	1250/5A	XM20-411141S000000	1250/1A	20	20	15
XMER 86-60	XM20-425141S000000	1500/5A	XM20-421141S000000	1500/1A	20	20	15
XMER 86-60	XM20-435141S000000	1600/5A	XM20-431141S000000	1600/1A	20	20	15

**Omega XMER Current Transformers single pole, Ø 54mm, Busbar 60x12.5, 50x30 & 40x40mm (H&V)**

Series	MPN	Ratio	MPN	Ratio	VA Kl. 1	VA Kl. 0.5	VA Kl. 0.2
XMER 104-60	XM21-275121S000000	250/5A	XM21-271121S000000	250/1A	12,5	7,5	1,5
XMER 104-60	XM21-285131S000000	300/5A	XM21-281131S000000	300/1A	15	10	2,5
XMER 104-60	XM21-315131S000000	400/5A	XM21-311131S000000	400/1A	15	10	3,75
XMER 104-60	XM21-325141S000000	500/5A	XM21-321141S000000	500/1A	20	15	7,5
XMER 104-60	XM21-335151S000000	600/5A	XM21-331151S000000	600/1A	30	15	10
XMER 104-60	XM21-365151S000000	750/5A	XM21-361151S000000	750/1A	30	20	15
XMER 104-60	XM21-375151S000000	800/5A	XM21-371151S000000	800/1A	30	30	15
XMER 104-60	XM21-395161S000000	1000/5A	XM21-391161S000000	1000/1A	45	30	20
XMER 104-60	XM21-405161S000000	1200/5A	XM21-401161S000000	1200/1A	45	30	30
XMER 104-60	XM21-415161S000000	1250/5A	XM21-411161S000000	1250/1A	45	30	30
XMER 104-60	XM21-425161S000000	1500/5A	XM21-421161S000000	1500/1A	45	30	30
XMER 104-60	XM21-435161S000000	1600/5A	XM21-431161S000000	1600/1A	45	30	30

**XMER 86-60**

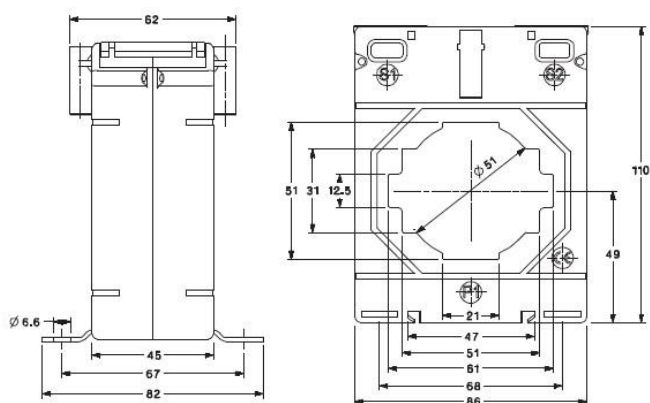

**XMER 104-60**

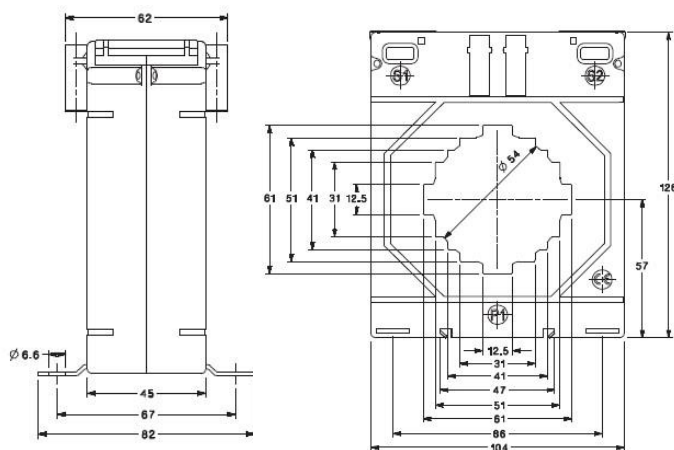

<b>Omega XMER Current Transformers single pole, Ø 65mm, Busbar 60x30 &amp; 50x50 &amp; 80x12,5mm</b>							
Series	MPN	Ratio	MPN	Ratio	VA Kl. 1	VA Kl. 0.5	VA Kl. 0.2
XMER 104-80	XM22-285101S000000	300/5A	XM22-281101S000000	300/1A	7,5	1,5	-
XMER 104-80	XM22-315111S000000	400/5A	XM22-311111S000000	400/1A	10	5	1,5
XMER 104-80	XM22-325111S000000	500/5A	XM22-321111S000000	500/1A	10	5	1,5
XMER 104-80	XM22-335121S000000	600/5A	XM22-331121S000000	600/1A	12,5	7,5	2,5
XMER 104-80	XM22-365131S000000	750/5A	XM22-361131S000000	750/1A	15	10	5
XMER 104-80	XM22-375131S000000	800/5A	XM22-371131S000000	800/1A	15	10	7,5
XMER 104-80	XM22-395141S000000	1000/5A	XM22-391141S000000	1000/1A	20	20	12,5
XMER 104-80	XM22-405151S000000	1200/5A	XM22-401151S000000	1200/1A	30	20	15
XMER 104-80	XM22-415151S000000	1250/5A	XM22-411151S000000	1250/1A	30	20	15
XMER 104-80	XM22-425151S000000	1500/5A	XM22-421151S000000	1500/1A	30	20	15
XMER 104-80	XM22-435151S000000	1600/5A	XM22-431151S000000	1600/1A	30	20	15
XMER 104-80	XM22-445151S000000	2000/5A	XM22-441151S000000	2000/1A	30	20	15
<b>Omega XMER Current Transformers single pole, Ø 73mm, Busbar 80x30 &amp; 50x60mm (H&amp;V)</b>							
Series	MPN	Ratio	MPN	Ratio	VA Kl. 1	VA Kl. 0.5	VA Kl. 0.2
XMER 140-80	XM23-285105S000000	300/5A	XM23-281105S000000	300/1A	15	7,5	1,5
XMER 140-80	XM23-315115S000000	400/5A	XM23-311115S000000	400/1A	20	10	2,5
XMER 140-80	XM23-325135S000000	500/5A	XM23-321135S000000	500/1A	30	15	5
XMER 140-80	XM23-335151S000000	600/5A	XM23-331151S000000	600/1A	30	15	7,5
XMER 140-80	XM23-365161S000000	750/5A	XM23-361161S000000	750/1A	45	15	10
XMER 140-80	XM23-375161S000000	800/5A	XM23-371161S000000	800/1A	45	15	10
XMER 140-80	XM23-395171S000000	1000/5A	XM23-391171S000000	1000/1A	60	30	15
XMER 140-80	XM23-405171S000000	1200/5A	XM23-401171S000000	1200/1A	60	30	15
XMER 140-80	XM23-415171S000000	1250/5A	XM23-411171S000000	1250/1A	60	60	30
XMER 140-80	XM23-425161S000000	1500/5A	XM23-421161S000000	1500/1A	60	60	30
XMER 140-80	XM23-435171S000000	1600/5A	XM23-431171S000000	1600/1A	60	60	30
XMER 140-80	XM23-445171S000000	2000/5A	XM23-441171S000000	2000/1A	60	60	30

**Omega XMER Current Transformers single pole, Ø 44mm, Busbar 60x30 & 50x40mm**

Series	MPN	Ratio	MPN	Ratio	VA Kl. 1	VA Kl. 0.5	VA Kl. 0.2
XMER 85-60	XB30-315081S000000	400/5A	XB30-311081S000000	400/1A	5	2,5	-
XMER 85-60	XB30-325111S000000	500/5A	XB30-321111S000000	500/1A	10	5	-
XMER 85-60	XB30-335111S000000	600/5A	XB30-331111S000000	600/1A	10	5	-
XMER 85-60	XB30-365111S000000	750/5A	XB30-331111S000000	750/1A	10	5	-
XMER 85-60	XB30-375111S000000	800/5A	XB30-361111S000000	800/1A	10	5	-
XMER 85-60	XB30-385111S000000	1000/5A	XB30-371111S000000	1000/1A	10	5	-
XMER 85-60	XB30-395111S000000	1200/5A	XB30-391111S000000	1200/1A	15	5	-

**Omega XMER Current Transformers single pole, Ø 30mm, Busbar 60x30 mm**

Series	MPN	Ratio	MPN	Ratio	VA Kl. 1	VA Kl. 0.5	VA Kl. 0.2
XMER 88-60	XB32-39511S000000	1000/5A	XB32-39111S000000	1000/1A	10	5	-
XMER 88-60	XB32-40511S000000	1200/5A	XB32-40111S000000	1200/1A	10	5	-
XMER 88-60	XB32-42511S000000	1500/5A	XB32-42111S000000	1500/1A	10	5	-
XMER 88-60	XB32-43511S000000	1600/5A	XB32-43111S000000	1600/1A	10	5	-
XMER 88-60	XB32-44513S000000	2000/5A	XB32-44113S000000	2000/1A	10	5	-

**XMER 104-80**

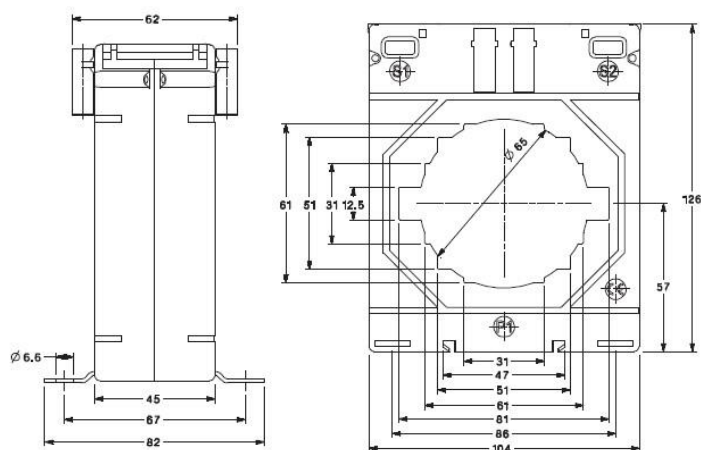

**XMER 140-80**

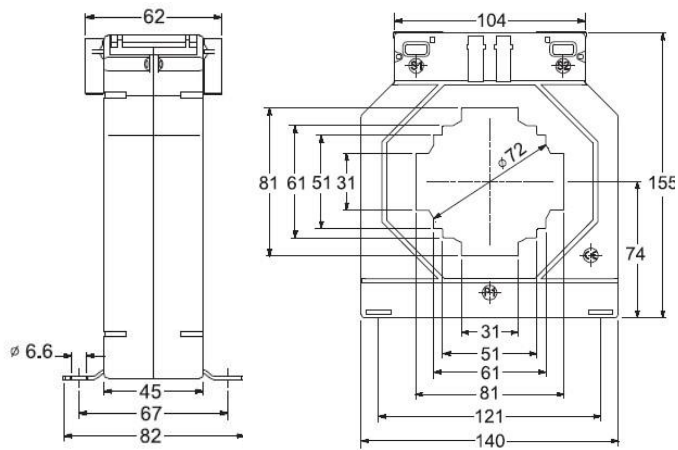

**XMER 85-60**

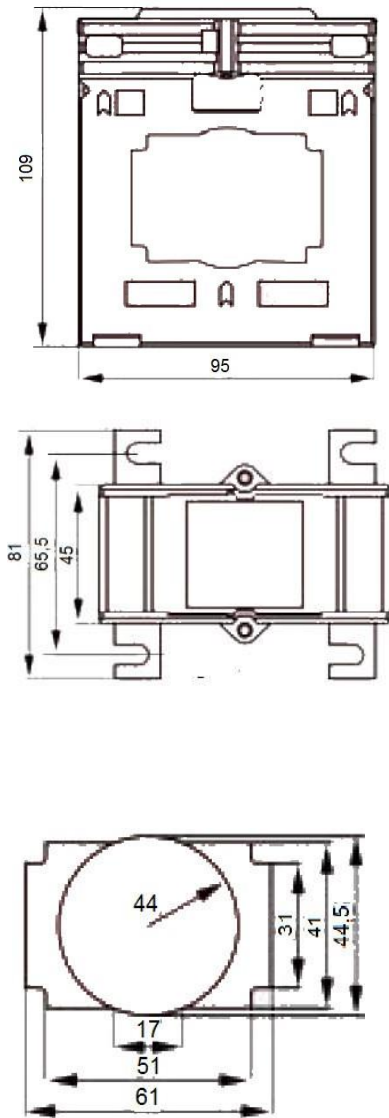

**XMER 88-60**

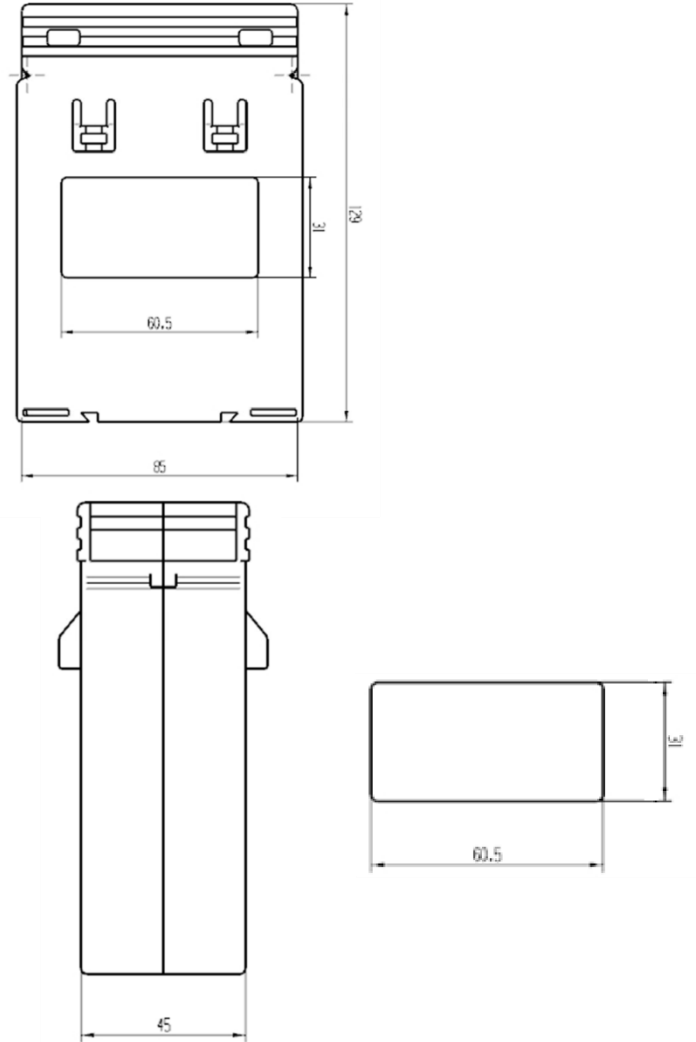

**Omega XMER Current Transformers single pole, Ø 86mm, Busbar 60x70 & 70x60, 80x60 & 100x30mm**

Series	MPN	Ratio	MPN	Ratio	VA Kl. 1	VA Kl. 0.5	VA Kl. 0.2
XMER 140-100H	XM24-325115S000000	500/5A	XM24-321115S000000	500/1A	12,5	10	2,5
XMER 140-100H	XM24-335131S000000	600/5A	XM24-331131S000000	600/1A	15	10	3,75
XMER 140-100H	XM24-355141S000000	750/5A	XM24-351141S000000	750/1A	20	12,5	5
XMER 140-100H	XM24-375141S000000	800/5A	XM24-371141S000000	800/1A	20	15	5
XMER 140-100H	XM24-395141S000000	1000/5A	XM24-391141S000000	1000/1A	20	15	10
XMER 140-100H	XM24-405151S000000	1200/5A	XM24-401151S000000	1200/1A	30	15	15
XMER 140-100H	XM24-415151S000000	1250/5A	XM24-411151S000000	1250/1A	30	15	15
XMER 140-100H	XM24-425151S000000	1500/5A	XM24-421151S000000	1500/1A	30	30	20
XMER 140-100H	XM24-435161S000000	1600/5A	XM24-431161S000000	1600/1A	45	45	20
XMER 140-100H	XM24-445161S000000	2000/5A	XM24-441161S000000	2000/1A	45	45	30
XMER 140-100H	XM24-465161S000000	2500/5A	XM24-461161S000000	2500/1A	45	45	30
XMER 140-100H	XM24-485171S000000	3000/5A	XM24-481171S000000	3000/1A	60	60	30

**Omega XMER Current Transformers single pole, Busbar 101x55 mm**

Series	MPN	Ratio	MPN	Ratio	VA Kl. 1	VA Kl. 0.5	VA Kl. 0.2
XMER 130-100	XR06-365111S000000	750/5A	XR06-361111S000000	750/1A	10	5	-
XMER 130-100	XR06-375111S000000	800/5A	XR06-371111S000000	800/1A	10	5	-
XMER 130-100	XR06-395131S000000	1000/5A	XR06-391131S000000	1000/1A	15	5	-
XMER 130-100	XR06-405131S000000	1200/5A	XR06-401131S000000	1200/1A	15	10	-
XMER 130-100	XR06-425131S000000	1500/5A	XR06-421131S000000	1500/1A	15	10	-
XMER 130-100	XR06-435131S000000	1600/5A	XR06-431131S000000	1600/1A	15	10	-
XMER 130-100	XR06-445131S000000	2000/5A	XR06-441131S000000	2000/1A	15	10	-
XMER 130-100	XR06-465131S000000	2500/5A	XR06-461131S000000	2500/1A	15	10	-
XMER 130-100	XR06-485131S000000	3000/5A	XR06-481131S000000	3000/1A	15	10	-
XMER 130-100	XR06-515131S000000	4000/5A	XR06-511131S000000	4000/1A	15	10	-

### XMER 140-100H

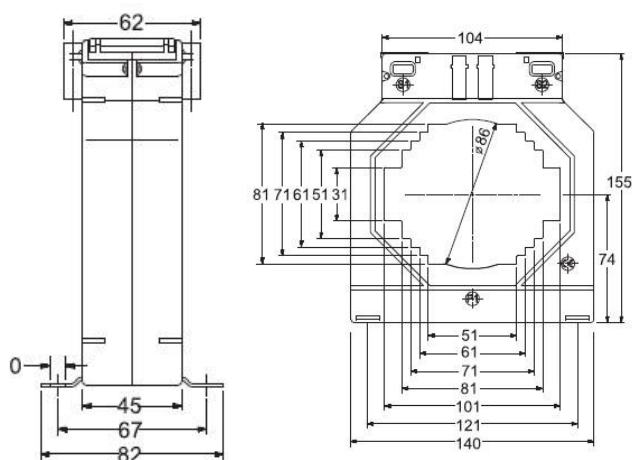

### XMER 130-100

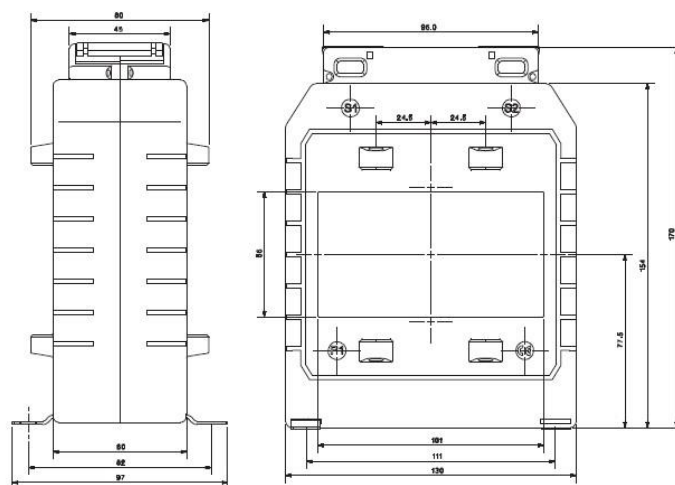

#### Omega XMER Current Transformers single pole, Busbar 93x125 mm

Series	MPN	Ratio	MPN	Ratio	VA Kl. 1	VA Kl. 0.5	VA Kl. 0.2
XMER 225-125	XR04-395131S000000	1000/5A	XR04-391131S000000	1000/1A	15	10	10
XMER 225-125	XR04-405131S000000	1200/5A	XR04-401131S000000	1200/1A	15	10	10
XMER 225-125	XR04-415131S000000	1250/5A	XR04-411131S000000	1250/1A	15	10	10
XMER 225-125	XR04-425151S000000	1500/5A	XR04-421151S000000	1500/1A	30	15	10
XMER 225-125	XR04-435151S000000	1600/5A	XR04-431151S000000	1600/1A	30	15	10
XMER 225-125	XR04-445151S000000	2000/5A	XR04-441151S000000	2000/1A	30	15	10
XMER 225-125	XR04-465151S000000	2500/5A	XR04-461151S000000	2500/1A	30	30	10
XMER 225-125	XR04-485171S000000	3000/5A	XR04-481171S000000	3000/1A	60	30	15
XMER 225-125	XR04-515171S000000	4000/5A	XR04-511171S000000	4000/1A	60	45	15
XMER 225-125	XR04-525181S000000	5000/5A	XR04-521181S000000	5000/1A	100	100	30
XMER 225-125	XR04-535181S000000	6000/5A	XR04-531181S000000	6000/1A	100	100	60

#### Omega XMER Current Transformers single pole, Busbar 128x38mm vertical

Series	MPN	Ratio	MPN	Ratio	VA Kl. 1	VA Kl. 0.5	VA Kl. 0.2
XMER 100-130V	XR02-335081S000000	600/5A	XR02-331081S000000	600/1A	5	2,5	-
XMER 100-130V	XR02-365081S000000	750/5A	XR02-361081S000000	750/1A	5	2,5	-
XMER 100-130V	XR02-375111S000000	800/5A	XR02-371111S000000	800/1A	10	5	-
XMER 100-130V	XR02-395131S000000	1000/5A	XR02-391131S000000	1000/1A	15	10	-
XMER 100-130V	XR02-405131S000000	1200/5A	XR02-401131S000000	1200/1A	15	10	-



XMER 100-130V	XR02-415131S000000	1250/5A	XR02-411131S000000	1250/1A	15	10	-
XMER 100-130V	XR02-425151S000000	1500/5A	XR02-421151S000000	1500/1A	30	15	-
XMER 100-130V	XR02-435151S000000	1600/5A	XR02-431151S000000	1600/1A	30	15	-
XMER 100-130V	XR02-445151S000000	2000/5A	XR02-441151S000000	2000/1A	12,5	10	-
XMER 100-130V	XR02-466151S000000	2500/5A	-	-	-	-	-
XMER 100-130V	XR02-486121S000000	3000/5A	-	-	-	-	-

### XMER 225-125

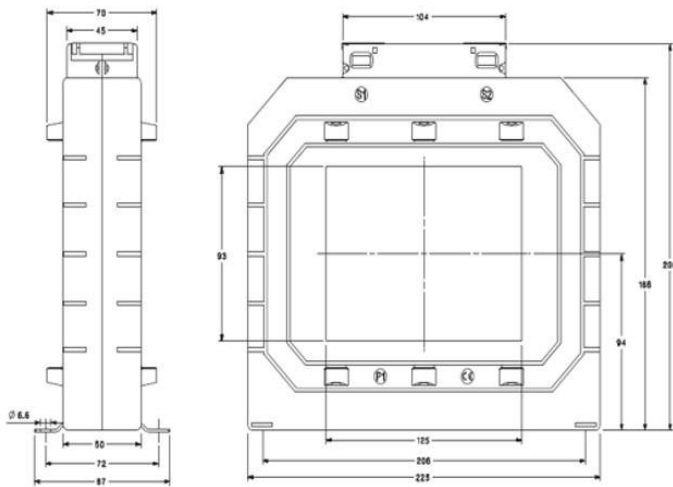

### XMER 100-130V

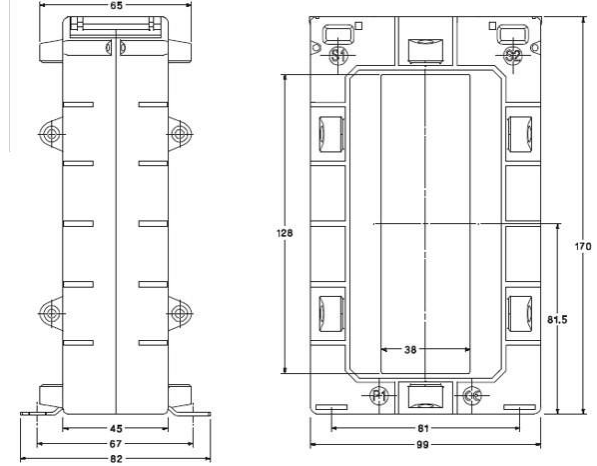

### Wound primary measuring current transformers

Omega XMER Current Transformers single pole, terminal connection							
Series	MPN	Ratio	MPN	Ratio	VA Kl. 1	VA Kl. 0.5	VA Kl. 0.2
XMER 62-W (40)	XW01-045081S000000	5/5A	XW01-041081S000000	5/1A	5	2,5	1
XMER 62-W (40)	XW01-065081S000000	10/5A	XW01-061081S000000	10/1A	5	2,5	1
XMER 62-W (40)	XW01-075081S000000	15/5A	XW01-071081S000000	15/1A	5	2,5	1
XMER 62-W (40)	XW01-085081S000000	20/5A	XW01-081081S000000	20/1A	5	2,5	1
XMER 62-W (40)	XW01-095081S000000	25/5A	XW01-091081S000000	25/1A	5	2,5	1
XMER 62-W (40)	XW01-105081S000000	30/5A	XW01-101081S000000	30/1A	5	2,5	1
XMER 74-W (45)	XW02-115111S000000	40/5A	XW02-111081S000000	40/1A	10	5	1,5
XMER 74-W (45)	XW02-135111S000000	50/5A	XW02-131111S000000	50/1A	10	5	-
XMER 74-W (45)	XW02-145111S000000	60/5A	XW02-141111S000000	60/1A	10	5	-

**XMER 62-W (40)**

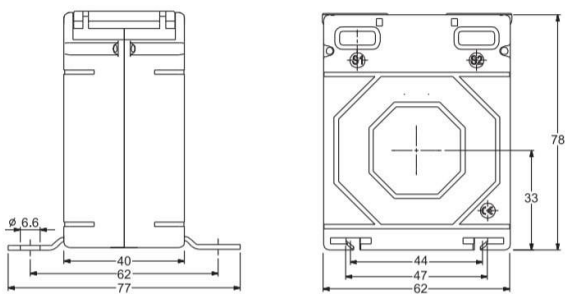

**XMER 74-W (45)**

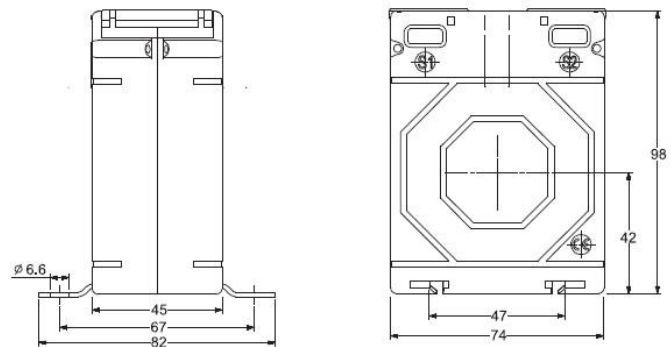

>

### Split Core measuring current transformers

Omega 10, 1-polig, Inner dimensions 33x33 mm				Omega 10, 1-polig, Inner dimensions 80x50mm			
Series	MPN	Ratio	VA Kl. 1	Series	MPN	Ratio	VA Kl. 1
Omega 10A	XS01-185031S000000	100/5A	1,5	Omega 10B	XS02-275051S000000	250/5A	2,5
Omega 10A	XS01-225221S000000	150/5A	1,75	Omega 10B	XS02-285071S000000	300/5A	3,75
Omega 10A	XS01-245051S000000	200/5A	2,5	Omega 10B	XS02-315071S000000	400/5A	3,75
Omega 10A	XS01-275071S000000	250/5A	3,75	Omega 10B	XS02-325081S000000	500/5A	5
-	-	-	-	-	XS02-335101S000000	600/5A	7,5
-	-	-	-	-	XS02-375111S000000	800/5A	10
-	-	-	-	-	XS02-395131S000000	1000/5A	15
Omega 10, 1-polig, Inner dimensions 120x80 mm				Omega 10, 1-polig, Inner dimensions 160x80 mm			
Omega 10C	XS03-375111S000000	800/5A	10	Omega 10D	XS04-435151S000000	1600/5A	30
Omega 10C	XS03-395131S000000	1000/5A	15	Omega 10D	XS04-445151S000000	2000/5A	30
Omega 10C	XS03-405151S000000	1200/5A	30	Omega 10D	XS04-465151S000000	2500/5A	30
Omega 10C	XS03-415151S000000	1250/5A	30	Omega 10D	XS04-48161S000000	3000/5A	45
Omega 10C	XS03-425161S000000	1500/5A	45	Omega 10D	XS04-515161S000000	4000/5A	45
Omega 10C	XS03-435161S000000	1600/5A	45	Omega 10D	XS04-525161S000000	5000/5A	45
Omega 10C	XS03-445161S000000	2000/5A	45	-	-	-	-
Omega 10C	XS03-465161S000000	2500/5A	45	-	-	-	-
Omega 10C	XS03-485161S000000	3000/5A	45	-	-	-	-



**Omega 10A**

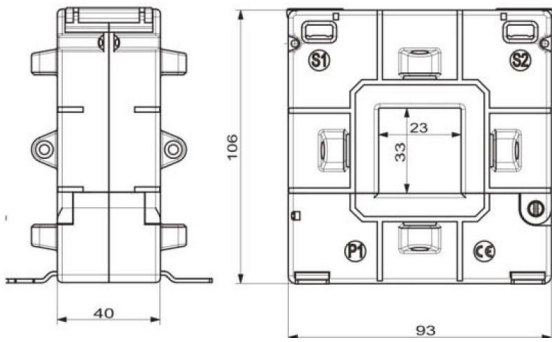

**Omega 10B**

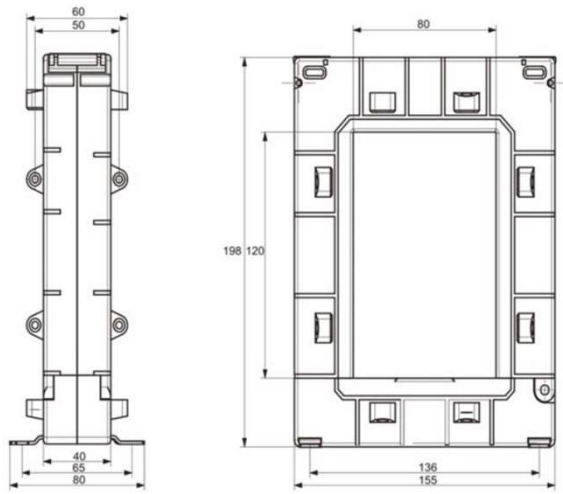
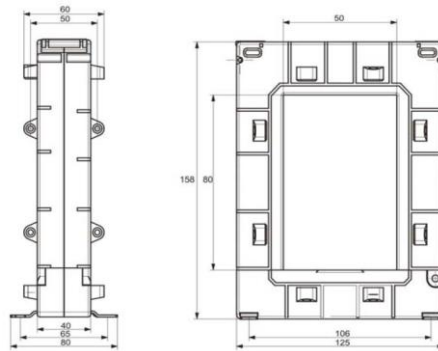

**Omega 10C**

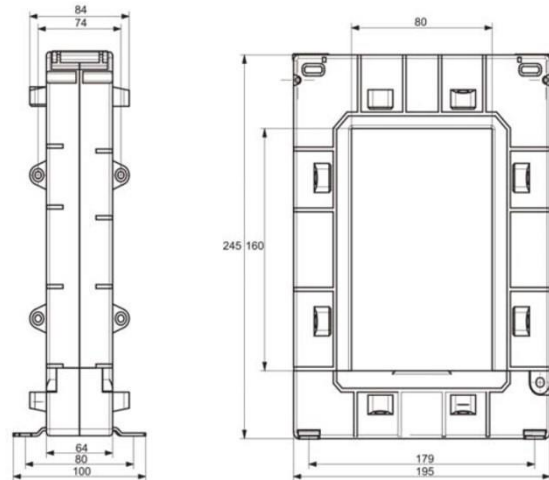

**Omega 10D**

## Through hole and busbar measuring current transformers – Multi Ratio

1-polig, Ø 31mm, Busbar 40x10, 30x20 & 15x30mm				1-polig, Ø 35mm, Busbar 40x12.5, 30x30 & 12,5x40mm			
Series	MPN	Ratio	VA Kl. 1	Series	MPN	Ratio	VA Kl. 1
XMER 62-40	XM13-XXXXXXXXXX	800-400-200/5A	10-5-2,5	XMER 74-40	XM16-XXXXXXXXXX	800-400-200/5A	10-5-2,5
-	-	-	-	XMER 74-40	XM16-XXXXXXXXXX	1000-500-250/5A	10-5-2,5
1-polig, Ø 41mm, Busbar 50x12.5, 40x20 & 30x30mm				1-polig, Ø 51 & 61x12,5 & 31x51, 30x40, 21x51 mm			
Series	MPN	Ratio	VA Kl. 1	Series	MPN	Ratio	VA Kl. 1
XMER 74-50	XM17-XXXXXXXXXX	1000-600-400/5A	10-5-2,5	XMER 86-60	XM20-XXXXXXXXXX	1000-600-400/5	10-5-2,5
1-polig, Ø 54mm, Busbar 60x12.5, 50x30 & 40x40mm (H&V)							
Series	MPN	Ratio	VA Kl. 1	Series	MPN	Ratio	VA Kl. 1
XMER 104-60	XM21-XXXXXXXXXX	1000-600-400/5	10-5-2,5	-	-	-	-

**XMER 62-40**

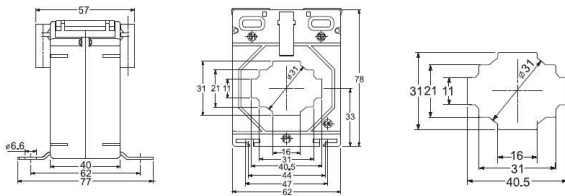

**XMER 74-40**

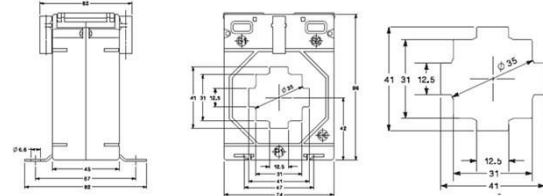

**XMER 74-50**

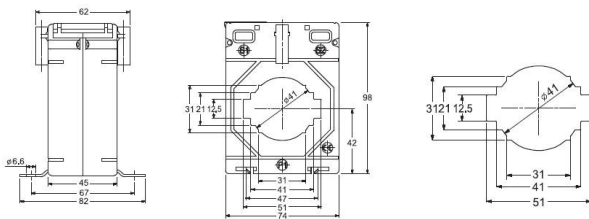

**XMER 86-60**

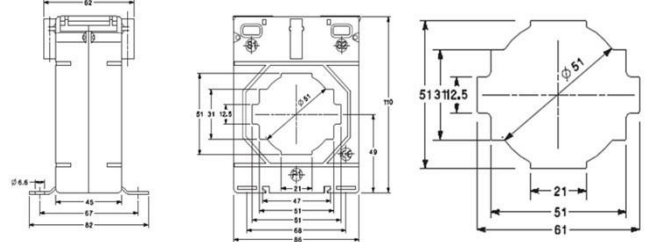



**XMER 104-60**

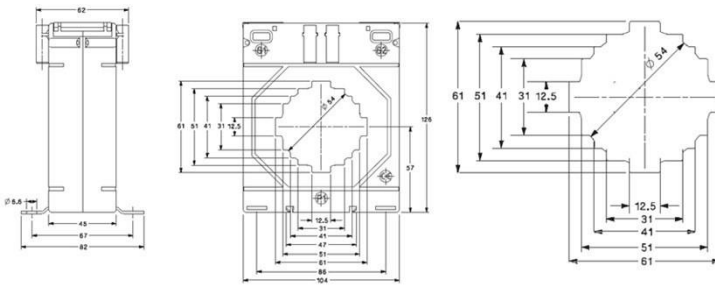



### 3 in 1 measuring current transformers

XN25/XN35/XN45, 60/5A bis 630/5A					
Series	MPN	Ratio	VA Kl. 1	Inner dimensions (BxH)	Center Distance
XN25	XN25-145011S000000	50/5A	1	3 x 15 x 25 mm	25mm
XN25	XN25-185031S000000	60/5A	1,5	3 x 15 x 25 mm	25mm
XN25	XN25-205031S000000	75/5A	1,5	3 x 15 x 25 mm	25mm
XN25	XN25-225031S000000	80/5A	1,5	3 x 15 x 25 mm	25mm
XN25	XN25-235031S000000	100/5A	1,5	3 x 15 x 25 mm	25mm
XN25	XN35-145031S000000	60/5A	1,5	3 x 21 x 25 mm	35mm
XN35	XN35-185031S000000	100/5A	1,5	3 x 21 x 25 mm	35mm
XN35	XN35-205031S000000	125/5A	1,5	3 x 21 x 25 mm	35mm
XN35	XN35-225031S000000	150/5A	1,5	3 x 21 x 25 mm	35mm
XN35	XN35-235031S000000	160/5A	1,5	3 x 21 x 25 mm	35mm
XN35	XN35-245031S000000	200/5A	1,5	3 x 21 x 25 mm	35mm
XN35	XN35-275031S000000	250/5A	1,5	3 x 21 x 25 mm	35mm
XN45	XN45-275031S000000	250/5A	1,5	3 x 31 x 31 mm	45mm
XN45	XN45-285051S000000	300/5A	2,5	3 x 31 x 31 mm	45mm
XN45	XN45-315051S000000	400/5A	2,5	3 x 31 x 31 mm	45mm
XN45	XN45-325051S000000	500/5A	2,5	3 x 31 x 31 mm	45mm
XN45	XN45-335051S000000	600/5A	2,5	3 x 31 x 31 mm	45mm
XN45	XN45-345051S000000	630/5A	2,5	3 x 31 x 31 mm	45mm

#### Technical data

System Voltage:	720V 50/60Hz
Primary current:	60A to 630A AC
Test voltage:	3 kV for 1 minute
Thermal short circuit current:	$I_{th} = 60 \times I_n$
Dynamic short circuit current:	$I_{dyn} = 2,55 \times I_{th}$
Case material:	self-extinguishing polycarbonate in accordance to UL94V-0
Standards:	IEC/EN 60044-1, IEC 61869-1, IEC 61010-2
Fixing:	Busbar, fixing feet, DIN-rail fixing

**XN25**

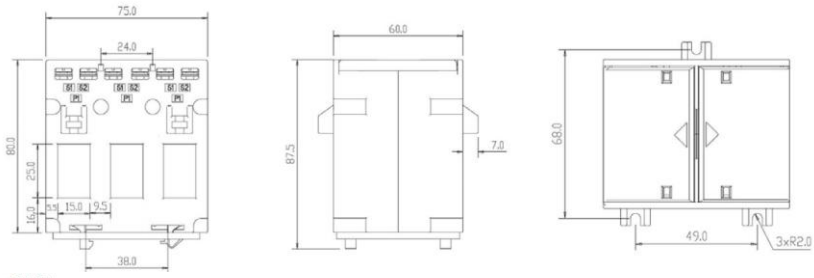

**XN35**

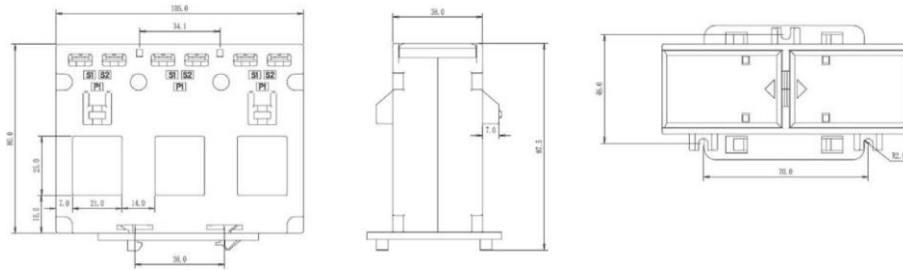

**XN45**

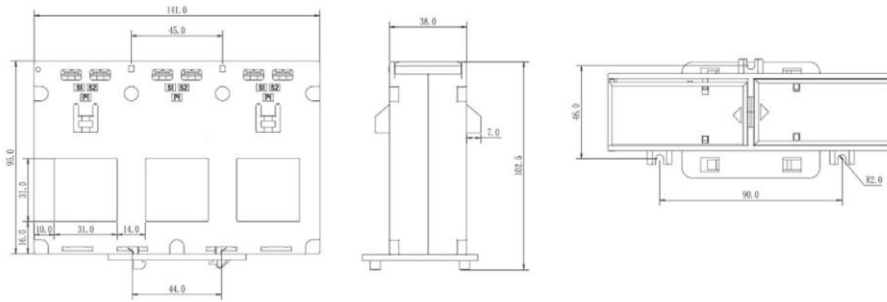





## Overview additional current transformers

We offer the full range of Sifam Tinsley Instrumentation current transformers.  
If you miss a current transformer for your dedicated application, we will be glad to assist.

### Overview additional current transformers from Sifam Tinsley instrumentation

#### Resin casted current transformers

- several versions
- 100 to 1200A nominal current



#### Ring type current transformers

- several versions
- 50 to 3200A nominal current



#### Current transformers with accuracy 0,2s

- several versions
- 100 to 7500A nominal current



#### Current transformers to ANSI-Standard

- several versions
- 50 to 4000A nominal current

