



# LGE3M160120E

Silicon Carbide Power MOSFET



$V_{DS} = 1200\text{ V}$   
 $I_D@25^\circ\text{C} = 17\text{ A}$   
 $R_{DS(ON)} = 160\text{ m}\Omega$

## Features

- High Blocking Voltage with Low On-Resistance
- High Speed Switching with Low Capacitances
- Easy to Parallel and Simple to Drive
- Avalanche Ruggedness
- Halogen Free, RoHS Compliant

## Benefits

- Higher System Efficiency
- Reduced Cooling Requirements
- Increased Power Density
- Increased System Switching Frequency

## Applications

- Solar Inverters
- Switch Mode Power Supplies
- High Voltage DC/DC Converters
- Battery Chargers
- Motor Drives
- Pulsed Power applications

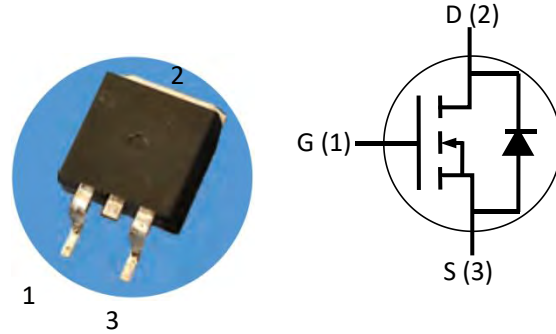

Part Number	Package
LGE3M160120E	D2PAK

## Maximum Ratings ( $T_c = 25^\circ\text{C}$ unless otherwise specified)

Symbol	Parameter	Value	Unit	Test Conditions	Note
$V_{DSmax}$	Drain - Source Voltage	1200	V	$V_{GS}=0\text{V}, I_D=100\mu\text{A}$	
$V_{GSmax}$	Gate - Source Voltage	-10/+25	V	Absolute maximum values	
$V_{GSop}$	Gate - Source Voltage	-5/+20	V	Recommended operational values	
$I_D$	Continuous Drain Current	17	A	$V_{GS}=20\text{V}, T_C=25^\circ\text{C}$	
		11		$V_{GS}=20\text{V}, T_C=100^\circ\text{C}$	
$I_{DM}$	Pulse Drain Current	38	A	Pulse width limited by $T_{jmax}$	
$P_D$	Power Dissipation	127	W	$T_C=25^\circ\text{C}, T_J=150^\circ\text{C}$	Fig. 10
$T_J, T_{stg}$	Operating Junction and Storage Temperature	-55 to +150	$^\circ\text{C}$		



### Electrical Characteristics

Symbol	Parameter	Min.	Typ.	Max.	Unit	Test Conditions	Note
$V_{(BR)DSS}$	Drain-Source Breakdown Voltage	1200			V	$V_{GS}=0V, I_D=100\mu A$	
$V_{GS(th)}$	Gate Threshold Voltage	2.0	2.4	4.0	V	$V_{GS}=V_{DS}, I_{DS}=2.5mA, T_C=25^\circ C$	Fig. 6
			1.8			$V_{GS}=V_{DS}, I_{DS}=2.5mA, T_C=150^\circ C$	
$I_{DSS}$	Zero Gate Voltage Drain Current		1	100	$\mu A$	$V_{DS}=1200V, V_{GS}=0V$	
$I_{GSS}$	Gate-Source Leakage Current		20	200	nA	$V_{GS}=20V, V_{DS}=0V$	
$R_{DS(on)}$	Drain-Source on-state Resistance		160	192	m $\Omega$	$V_{GS}=20V, I_D=10A, T_C=25^\circ C$	Fig. 4
			285			$V_{GS}=20V, I_D=10A, T_C=150^\circ C$	
$g_{fs}$	Transconductance		4.2		S	$V_{GS}=20V, I_D=10A, T_J=25^\circ C$	Fig. 5
			4.0			$V_{GS}=20V, I_D=10A, T_J=150^\circ C$	
$C_{iss}$	Input Capacitance		950		pF	$V_{GS}=0V, V_{DS}=1000V, f=1MHz$ $V_{AC}=25mV$	Fig. 8
$C_{oss}$	Output Capacitance		35.0				
$C_{rss}$	Reverse Transfer Capacitance		8.5				
$E_{ON}$	Turn-On Switching Energy		95		$\mu J$	$V_{DS}=800V, V_{GS}=-5/20V, I_D=10A,$ $R_{G(ext)}=2.5\Omega, L=256\mu H$	
$E_{OFF}$	Turn-Off Switching Energy		48				
$t_{d(on)}$	Turn-On Delay Time		12		ns	$V_{DD}=800V, V_{GS}=-5/20V$ $I_D=10A, R_{G(ext)}=2.5\Omega,$ $R_L=80\Omega, \text{Timing relative to } V_{DS}$	
$t_r$	Rise Time		20				
$t_{d(off)}$	Turn-Off Delay Time		15				
$t_f$	Fall Time		10				
$R_{G(int)}$	Internal Gate Resistance		5.8		$\Omega$	$f=1MHz, V_{AC}=25mV$	
$Q_{gs}$	Gate to Source Charge		9		nC	$V_{DD}=800V, V_{GS}=-5/20V$ $I_D=10A$	Fig. 9
$Q_{gd}$	Gate to Drain Charge		17				
$Q_g$	Total Gate Charge		42				

### Reverse Diode Characteristics

Symbol	Parameter	Typ.	Max.	Unit	Test Conditions	Note
$V_{SD}$	Diode Forward Voltage	3.5		V	$V_{GS}=-5V, I_{SD}=5A, T_J=25^\circ C$	Fig. 7
		3.3		V	$V_{GS}=-5V, I_{SD}=5A, T_J=150^\circ C$	
$I_S$	Continuous Diode Forward Current		17	A	$T_C=25^\circ C$	
$t_{rr}$	Reverse Recovery time	14		ns	$V_{GS}=-5V, I_{SD}=10A, V_R=800V,$ $dif/dt=1000A/\mu s;$	
$Q_{rr}$	Reverse Recovery Charge	44		nC		
$I_{rrm}$	Peak Reverse Recovery Current	6.0		A		

### Thermal Characteristics

Symbol	Parameter	Typ.	Unit	Test Conditions	Note
$R_{\theta JC}$	Thermal Resistance from Junction to Case	0.98	$^\circ C/W$		Fig. 11
$R_{\theta JA}$	Thermal Resistance From Junction to Ambient	40			



### Typical Performance

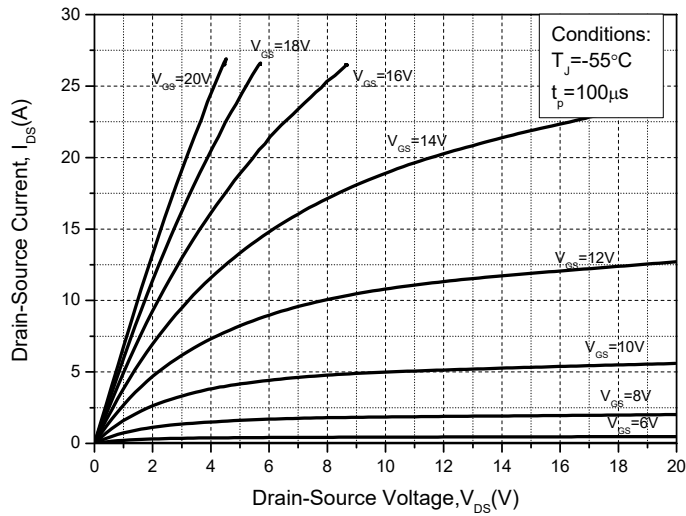

Figure 1. Output Characteristics  $T_j = -55^\circ\text{C}$

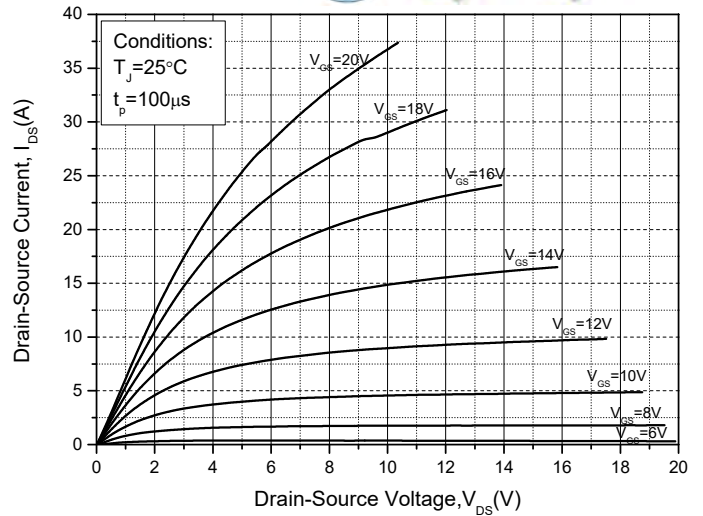

Figure 2. Output Characteristics  $T_j = 25^\circ\text{C}$

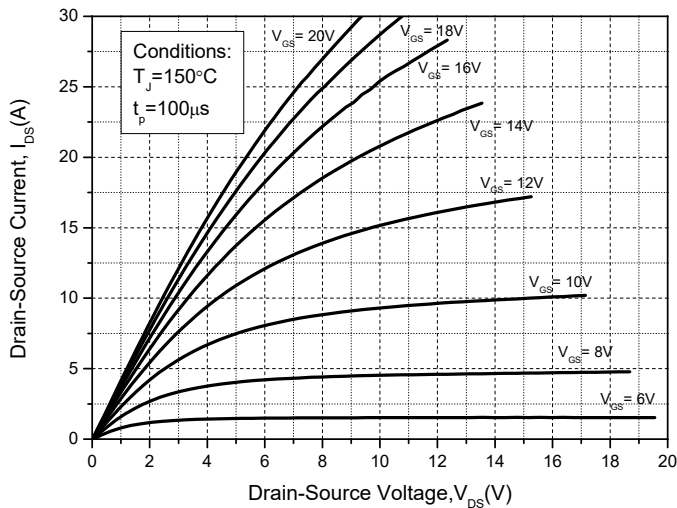

Figure 3. Output Characteristics  $T_j = 150^\circ\text{C}$

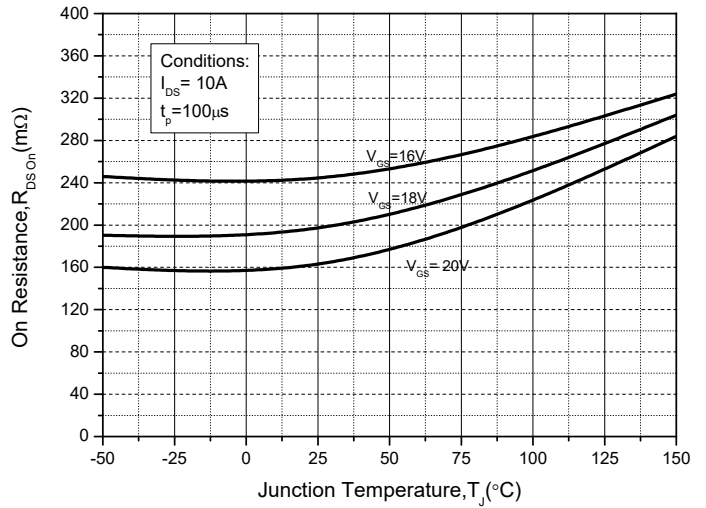

Figure 4. On-Resistance For Various Gate Voltage

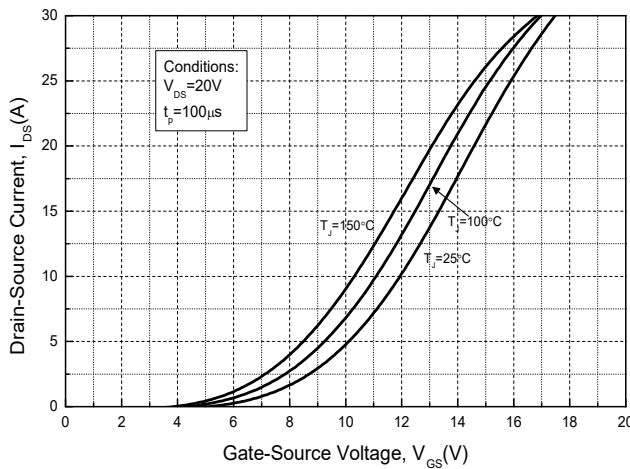

Figure 5. Transfer Characteristic

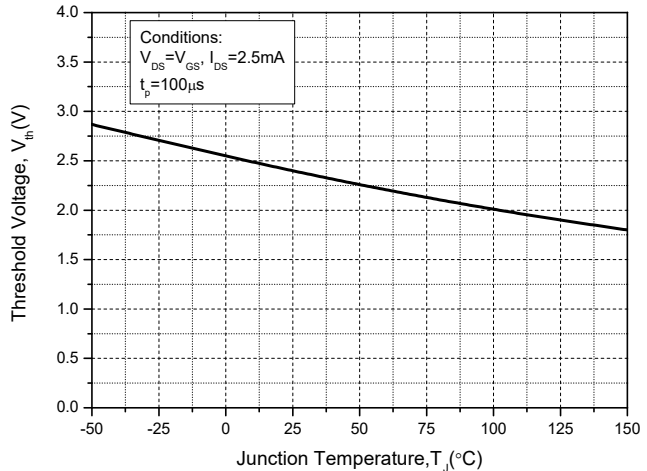

Figure 6. Threshold Voltage vs. Temperature for Various Junction Temperatures

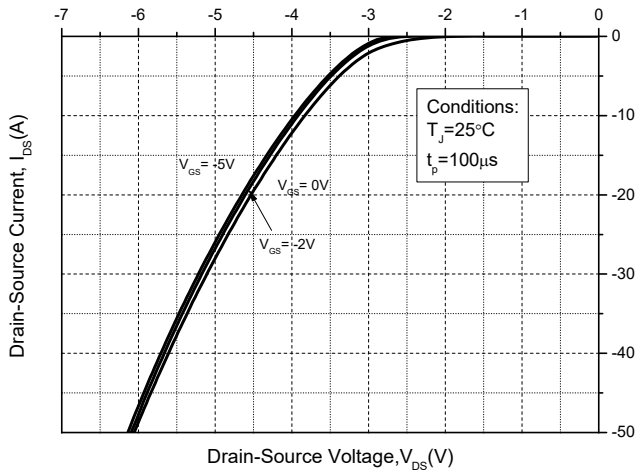

Figure 7. Body Diode Characteristics

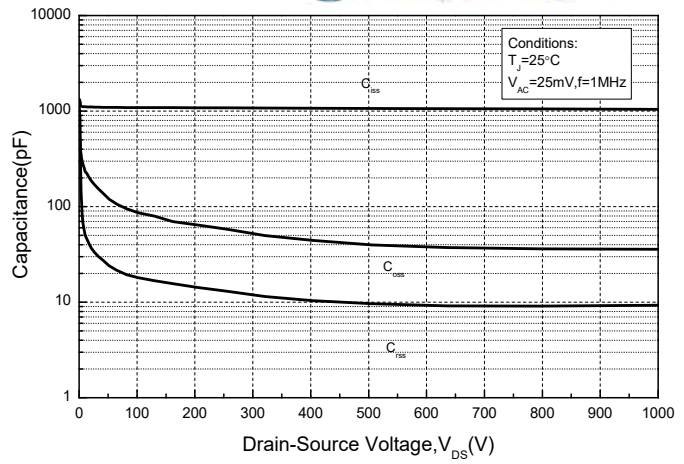

Figure 8. Capacitances vs. Drain-Source Voltage

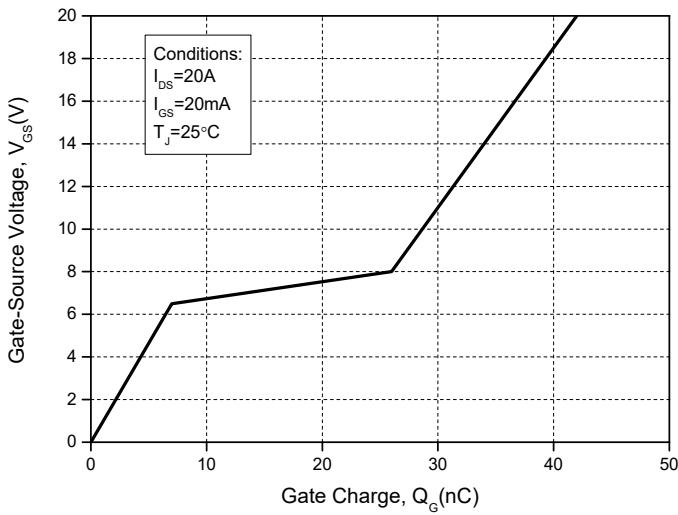

Figure 9. Gate Charge Characteristics

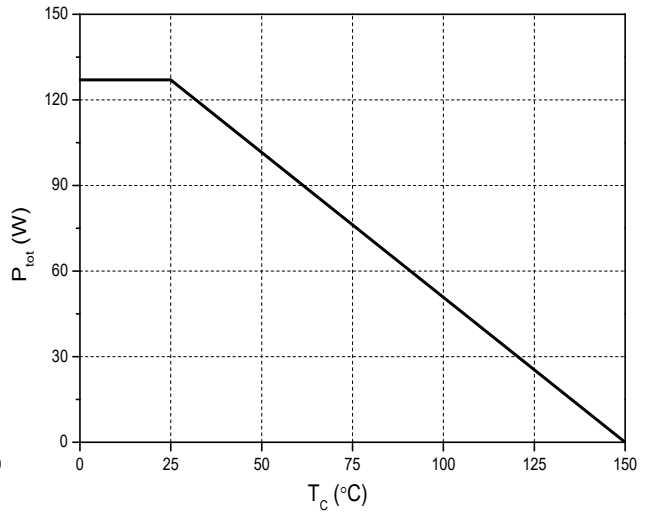

Figure 10. Power Dissipation Derating

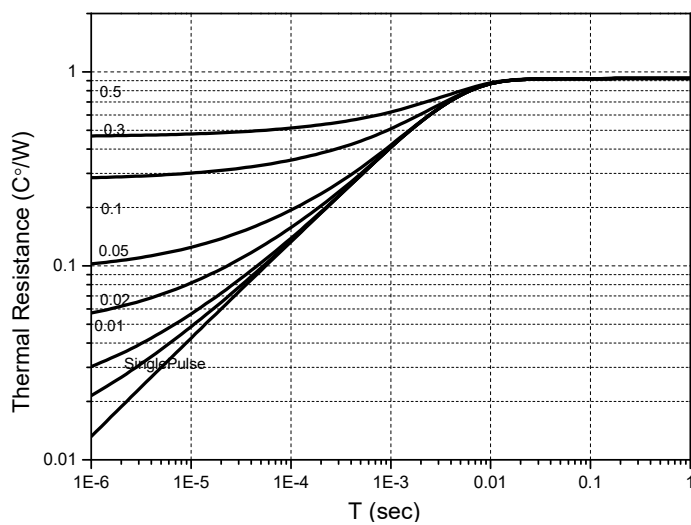

Figure 11. Transient Thermal Impedance



# LGE3M160120E

Silicon Carbide Power MOSFET



Package Dimensions: D2PAK

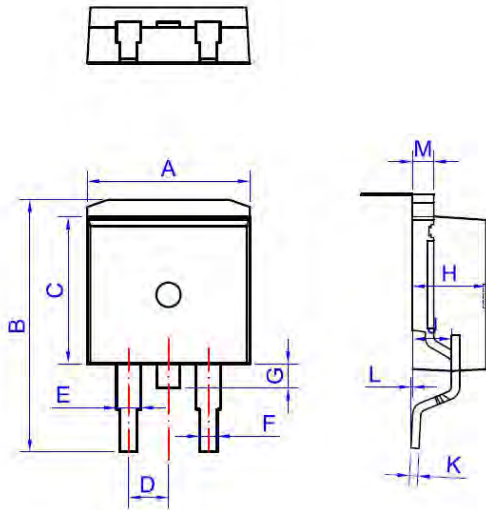

Ref.	Dimensions					
	Millimeters			Inches		
	Min.	Typ.	Max.	Min.	Typ.	Max.
A	9.90		10.20	0.390		0.402
B	14.70		15.80	0.579		0.622
C	9.4		9.6	0.37		0.378
D		2.54			0.100	
E	1.20		1.40	0.047		0.055
F	0.75		0.85	0.029		0.033
G			1.75			0.069
H	4.40		4.70	0.173		0.185
J	2.30		2.70	0.091		0.106
K	0.38		0.55	0.015		0.022
L	0	0.10	0.25	0	0.004	0.010
M	1.25		1.35	0.049		0.053