

B2, B3, B4, B5, B6 MEASURING SHUNTS

FEATURES:

Class 0.2 Class 0.5

1 A ... 18 kA DIN 35 mm

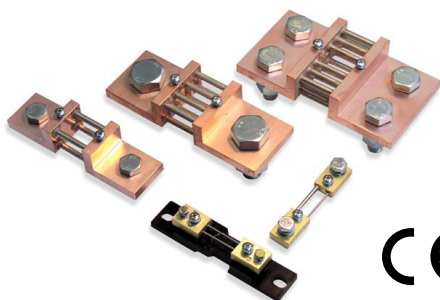

- Extension of d.c. current measuring ranges of moving-coil ammeters.
- **Accuracy class 0.2 for ranges ≤ 2500 A, class 0.5 for ranges > 2500 A.**
- Shunts of 1...25 A ranges (and on request, B2 40...150 A) are fixed on an isolating base.
- The isolating base is adapted to be assembled on a 35 mm DIN rail.
- On request, additional chemical coating are available: lackering or silver.

EXAMPLE OF APPLICATION

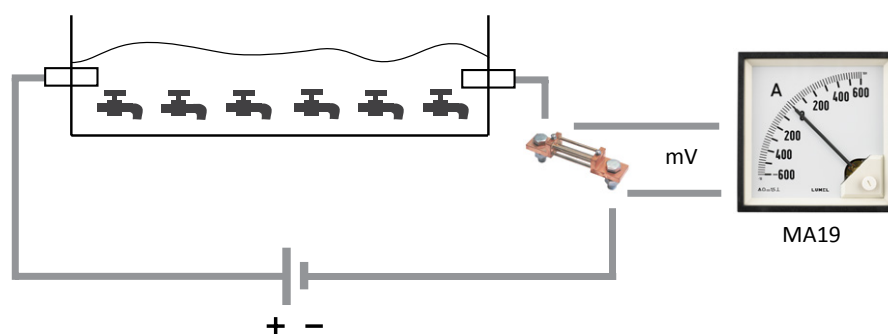

Process of fittings electroplating.

INPUT:



OUTPUTS:

50 mV 60 mV

75 mV 100 mV

150 mV

KIND OF VERSION

Version A (on an isolating base)

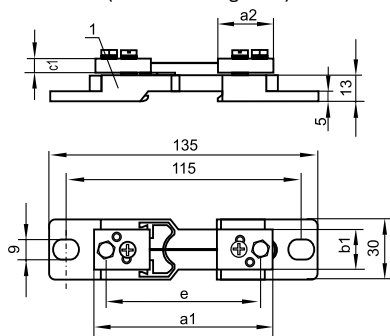

Version D

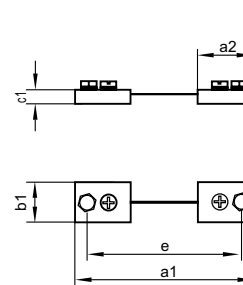

Version B

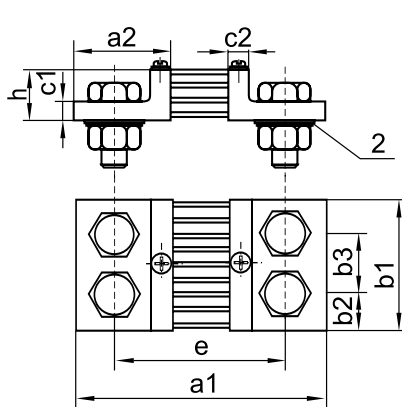

Version C

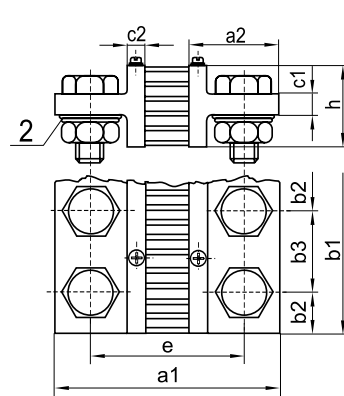

Fig.1. Fixing dimensions of shunts
1 - isolating base, 2 - round spring washer.

Export department:
English: +48 68 45 75
139/ 233/ 321/ 386
e-mail: export@lumel.com.pl

LUMEL S.A.
ul. Sulechowska 1
65-022 Zielona Góra
POLAND

WWW.LUMEL.COM.PL

B2, B3, B4, B5, B6 MEASURING SHUNTS

B2 60 mV												Current terminals			
IN [A]	Version	a1	a2	b1	b2	b3	c1	c2	e	h	Weight [kg]	LZ	Bolt	P	N
1; 1,5; 2; 2,5; 4;6; 5; 10; 12; 15; 20; 25; 30	A	90	28	20	-	-	8	-	78	-	0.13	2 x 1	M5 x 12	5.5	-
30; 40; 45;50; 60; 75; 80; 100; 120 125; 150; 160; 200	A, D	100	33	20	-	-	8	-	80	-	0.13	2 x 1	M8 x 16	8.5	-
200; 240;250; 300	B	145	55	30	15	-	10	10	105	30	0.60	2 x 1	M12 x 40	13	M12
300; 350; 400; 500	B	145	55	40	20	-	10	10	105	30	0.85	2 x 1	M16 x 45	17	M16
500; 600; 650; 750; 800	B	145	55	40	20	-	10	10	105	30	0.85	2 x 1	M16 x 45	17	M16
750; 800; 1000; 1200	B	165	65	60	30	-	10	10	115	30	1.45	2 x 1	M20 x 50	21	M20
1200; 1500; 2000	B	165	65	90	21	48	10	10	115	30	2.00	2 x 2	M16 x 45	17	M16
2000; 2500; 3000	B	165	65	120	30	60	10	10	115	30	2.90	2 x 2	M20 x 50	21	M20
3000; 4000; 5000	C	165	65	120	30	60	15	10	115	60	4.30	2 x 2	M20 x 60	21	M20
5000; 6000; 8000	C	175	70	154	25	52	25	15	125	130	10.50	2 x 3	M20 x 75	21	M20
8000; 10000; 12000	C	185	75	206	25	52	30	20	135	170	21.00	2 x 4	M20 x 80	21	M20
12000; 15000; 18000	C	185	75	310	25	52	30	20	135	170	32.00	2 x 6	M20 x 80	21	M20



B3 150 mV												Current terminals			
IN [A]	Version	a1	a2	b1	b2	b3	c1	c2	e	h	Weight [kg]	LZ	Bolt	P	N
1; 1,5; 2,5; 4; 5; 6; 10; 15; 20; 25	A	90	28	20	-	-	8	-	78	-	0.14	2 x 1	M5 x 12	5.5	-
30; 40; 50; 60; 75; 80;100; 125; 150; 160; 200	D	225	33	25	-	-	8	-	205	-	0.23	2 x 1	M8 x 16	8.5	-
200; 250; 300	B	270	55	30	15	-	10	10	230	50	0.68	2 x 1	M12 x 40	13	M12
300; 400; 500	B	270	55	40	20	-	10	10	230	50	1.05	2 x 1	M16 x 45	17	M16
500; 600; 750; 800	B	270	55	40	20	-	10	10	230	50	1.16	2 x 1	M16 x 45	17	M16
750; 800; 1000; 1200	B	290	65	70	35	-	10	10	240	50	2.15	2 x 1	M20 x 50	21	M20
1200; 1500; 2000	C	290	65	90	21	48	15	10	240	60	3.10	2 x 2	M16 x 60	17	M16
2000; 2500; 3000	C	290	65	120	30	60	15	10	240	60	5.20	2 x 2	M20 x 60	21	M20
3000; 4000; 5000	C	300	70	120	30	60	25	15	250	130	8.30	2 x 2	M20 x 75	21	M20
5000; 6000; 8000	C	300	70	154	25	52	25	15	250	130	15.00	2 x 3	M20 x 75	21	M20
8000; 10000	C	310	75	206	25	52	30	20	260	170	28.00	2 x 4	M20 x 80	21	M20
15000	C	310	75	310	25	52	30	20	260	170	35.00	2 x 6	M20 x 80	21	M20



B4 50 mV												Current terminals			
IN [A]	Version	a1	a2	b1	b2	b3	c1	c2	e	h	Weight [kg]	LZ	Bolt	P	N
1; 1,5; 2,5; 4; 5; 6;10; 15; 20; 25	A	90	28	20	-	-	8	-	78	-	0.13	2 x 1	M5 x 12	5.5	-
30; 40; 50; 60;75; 80; 100; 150; 160; 200	D	93	33	20	-	-	8	-	73	-	0.13	2 x 1	M8 x 16	8.5	-
200; 250; 300	B	138	55	30	15	-	10	10	98	30	0.60	2 x 1	M12 x 40	13	M12
300; 400; 500	B	138	55	40	20	-	10	10	98	30	0.85	2 x 1	M16 x 45	17	M16
500; 600; 750; 800	B	138	55	40	20	-	10	10	98	30	0.85	2 x 1	M16 x 45	17	M16
750; 800; 1000	B	158	65	60	30	-	10	10	108	30	1.45	2 x 1	M20 x 50	21	M20
1500; 2000	B	158	65	90	21	48	10	10	108	30	2.00	2 x 2	M16 x 45	17	M16
2000; 2500; 3000	B	158	65	120	30	60	10	10	108	30	2.90	2 x 2	M20 x 50	21	M20
3000; 4000; 5000	C	158	65	120	30	60	15	10	108	60	4.30	2 x 2	M20 x 60	21	M20
5000; 6000; 8000	C	168	70	154	25	52	25	15	118	130	10.50	2 x 3	M20 x 75	21	M20
8000; 10000; 12000	C	178	75	206	25	52	30	20	128	170	21.00	2 x 4	M20 x 80	21	M20
12000; 15000	C	178	75	310	25	52	30	20	128	170	32.00	2 x 6	M20 x 80	21	M20



Export department:
English: +48 68 45 75
139/ 233/ 321/ 386
e-mail: export@lumel.com.pl

LUMEL S.A.
ul. Sulechowska 1
65-022 Zielona Góra
POLAND
WWW.LUMEL.COM.PL

B2, B3, B4, B5, B6 MEASURING SHUNTS



B5 75 mV												Current terminals			
IN [A]	Version	a1	a2	b1	b2	b3	c1	c2	e	h	Weight [kg]	LZ	Bolt	P	N
1; 1,5; 2,5; 4; 5; 6; 10; 12; 15; 20; 25	A	90	28	20	-	-	8	-	78	-	0.14	2 x 1	M5 x 12	5.5	-
30; 40; 50; 75; 80; 60; 100; 125; 150; 160	D	115	33	25	-	-	8	-	95	-	0.17	2 x 1	M8 x 16	8.5	-
200; 250; 300	B	160	55	30	15	-	10	10	120	30	0.63	2 x 1	M12 x 40	13	M12
300; 400; 500	B	160	55	40	20	-	10	10	120	30	0.92	2 x 1	M16 x 45	17	M16
500; 600	B	160	55	40	20	-	10	10	120	30	1.00	2 x 1	M16 x 45	17	M16
750; 800; 1000; 1200	B	180	65	60	30	-	10	10	130	30	1.75	2 x 1	M20 x 50	21	M20
1200; 1500; 2000	B	180	65	120	30	60	10	10	130	30	2.30	2 x 2	M16 x 45	17	M16
2000; 2500; 3000	C	180	65	120	30	60	15	10	130	60	3.10	2 x 2	M20 x 60	21	M20
3000; 4000; 5000	C	190	70	120	30	60	25	15	140	130	5.20	2 x 2	M20 x 75	21	M20
5000; 6000; 8000	C	190	70	154	25	52	25	15	140	130	11.20	2 x 3	M20 x 75	21	M20
8000; 10000	C	200	75	206	25	52	30	20	150	170	22.00	2 x 4	M20 x 80	21	M20
15000	C	200	75	310	25	52	30	20	150	170	33.00	2 x 6	M20 x 80	21	M20

B6 100 mV												Current terminals			
IN [A]	Version	a1	a2	b1	b2	b3	c1	c2	e	h	Weight [kg]	LZ	Bolt	P	N
1; 1,5; 2,5; 4; 5; 6; 10; 15; 20; 25	A	90	28	20	-	-	8	-	78	-	0.14	2 x 1	M5 x 12	5.5	-
30; 40; 50; 60; 75; 80; 100; 125; 150; 160; 200	D	145	33	25	-	-	8	-	125	-	0.20	2 x 1	M8 x 16	8.5	-
200; 250; 300	B	190	55	30	15	-	10	10	150	30	0.65	2 x 1	M12 x 40	13	M12
300; 400; 500	B	190	55	40	20	-	10	10	150	30	1.00	2 x 1	M16 x 45	17	M16
500; 600; 750; 800	B	190	55	40	20	-	10	10	150	30	1.11	2 x 1	M16 x 45	17	M16
750; 800; 1000; 1200	B	210	65	60	30	-	10	10	160	30	2.00	2 x 1	M20 x 50	21	M20
1200; 1500; 2000	B	210	65	120	30	60	10	10	160	30	2.50	2 x 2	M16 x 45	17	M16
2000; 2500; 3000	C	210	65	120	30	60	15	10	160	60	3.20	2 x 2	M20 x 60	21	M20
3000; 4000; 5000	C	220	70	120	30	60	25	15	170	130	5.80	2 x 2	M20 x 75	21	M20
5000; 6000; 8000	C	220	70	154	25	52	25	15	170	130	12.00	2 x 3	M20 x 75	21	M20
8000; 10000	C	230	75	206	25	52	30	20	180	170	23.00	2 x 4	M20 x 80	21	M20
15000	C	230	75	310	25	52	30	20	180	170	34.00	2 x 6	M20 x 80	210	M20

IN - rated current LZ - number of terminals Bolt - hexagon bolt P - washer
 N - nut Voltage terminals - two M5 x 8 cylinder-head bolts with a cruciform cavity + 5.5 washers + 5.1 spring washers

TECHNICAL DATA		
Electromagnetic compatibility	noise immunity	acc. to EN 61000-6-2
	noise emissions	acc. to EN 61000-6-4
Overload range	continuously 5 s max. ≤ 2,000 A > 2,000...10,000 A	1.2 times rated current 5 times rated current 2 times rated current
Accuracy class	0.2 or 0.5 (acc. to ordering code)	
Additional error from ambient temperature	0.5 % / 10°C	
Climatic suitability	climatic class 3	acc. to VDE/VDI 3540
Operating temperature	-10...+55°C	
Storage temperature	-25...+65°C	
Relative humidity	≤ 75% annual average, non-condensing	
Shunt calibration	B2, B4, B5, B6 of 1 .. 10 A ranges	considering the 10 mA current of the meter measuring element
	B3 of 1 .. 4 A ranges	considering the 5 mA current of the meter measuring element
Shunts dimensions	acc. to DIN 43 703 standard	
Testing voltage of shunts with an isolating base	5 kV	
Resistance of a pair of wires connecting the shunt to the meter	35 mΩ or 75 Ω, wires are not delivered with the shunt	
Long-term overload	120%·In	
Short duration overload up tp 5 seconds	for range up to 2kA – 5·In for range 2kA <In<10kA – 2·In	

Export department:
 English: +48 68 45 75
 139/ 233/ 321/ 386
 e-mail: export@lumel.com.pl

LUMEL S.A.
 ul. Sulechowska 1
 65-022 Zielona Góra
 POLAND

WWW.LUMEL.COM.PL

ORDERING

	Shunt-	XX XXX	XXXXX	X	X	XX	X	X	
Voltage drop:									
60 mV		B2 060							
150 mV		B3 150							
50 mV		B4 050							
75 mV		B5 075							
100 mV		B6 100							
Measuring range and version:									
acc. to the Table 1, Range code column			XXXXX						
External coating:									
standard coating								0	
tropical coating								T	
total silver coating								R	
silver coating of current terminals								S	
Fixing bolts:									
without bolts								0	
with bolts								1	
Version:									
acc. to the Table 1, Version code column								XX	
Language version:									
multilanguage (Polish/English)									M
other (after agreeing with the manufacturer)									X
Acceptance tests:									
without extra quality inspection requirements, class 0.2*									0
with an extra quality inspection certificate, class 0.2*									1
with a checking certificate, class 0.2*									2
without extra quality inspection requirements, class 0.5									A
with an extra quality inspection certificate, class 0.5									B
with a checking certificate, class 0.5									C



* for ranges ≤ 2500 A

Example of order:

The ordering code: **B2 060-1A00A-0-1-00-M-1** means:

- B2 060** - shunt B2 with voltage drop 60 mV
- 1A00A** - measuring range: 1 A, version on an isolating base
- 0** - standard external coating
- 1** - with fixing bolts
- 00** - standard version
- M** - multilanguage version
- 1** - with an extra quality inspection certificate, class 0.2.

Table 1

Measuring range	Version (drawing)	B2 60mV		B3 150mV		B4 50mV		B5 75mV		B6 100mV	
		Range code	Version code	Range code	Version code	Range code	Version code	Range code	Version code	Range code	Version code
1A	A	1A00A	00	1A00A	00	1A00A	00	1A00A	00	1A00A	00
1.5A	A	1A50A	00	1A50A	00	1A50A	00	1A50A	00	1A50A	00
2A	A	2A00A	A1	-	-	-	-	-	-	-	-
2.5A	A	2A50A	00	2A50A	00	2A50A	00	2A50A	00	2A50A	00
4A	A	4A00A	00	4A00A	00	4A00A	00	4A00A	00	4A00A	00
5A	A	5A00A	A1	5A00A	A1	5A00A	A1	5A00A	A1	5A00A	A1
6A	A	6A00A	00	6A00A	00	6A00A	00	6A00A	00	6A00A	00
10A	A	10A0A	00	10A0A	00	10A0A	00	10A0A	00	10A0A	00
12A	A	12A0A	A1	-	-	-	-	12A0A	A1	-	-
15A	A	15A0A	00	15A0A	00	15A0A	00	15A0A	00	15A0A	00
20A	A	20A0A	A1	20A0A	A1	20A0A	A1	20A0A	A1	20A0A	A1
25A	A	25A0A	00	25A0A	00	25A0A	00	25A0A	00	25A0A	00

SEE ALSO:



Moving - coil meters of MA series.



Digital meters N24, N25.



Temperature and d.c. standard signals universal digital meter with OLED - N21

Export department:
English: +48 68 45 75
139/ 233/ 321/ 386
e-mail: export@lumel.com.pl

LUMEL S.A.
ul. Sulechowska 1
65-022 Zielona Góra
POLAND

WWW.LUMEL.COM.PL

B2, B3, B4, B5, B6 MEASURING SHUNTS



Programmable digital meter of temp., resistance and standard signals - N30U.

Measuring range	Version (drawing)	B2 60mV		B3 150mV		B4 50mV		B5 75mV		B6 100mV	
		Range code	Version code	Range code	Version code	Range code	Version code	Range code	Version code	Range code	Version code
30A, based on 25A	A	30A0A	A1	-	-	-	-	-	-	-	-
30A, based on 150A	A	30A0A	A2	-	-	-	-	-	-	-	-
30A, based on 150A	D	30A0D	A2	30A0D	A2	30A0D	A2	30A0D	A2	30A0D	A2
40A	A	40A0A	00	-	-	-	-	-	-	-	-
40A	D	40A0D	00	40A0D	00	40A0D	00	40A0D	00	40A0D	00
45A	A	45A0A	A2	-	-	-	-	-	-	-	-
45A	D	45A0D	A2	-	-	-	-	-	-	-	-
50A	A	50A0A	A2	-	-	-	-	-	-	-	-
50A	D	50A0D	A2	50A0D	A2	50A0D	A2	50A0D	A2	50A0D	A2
60A	A	60A0A	00	-	-	-	-	-	-	-	-
60A	D	60A0D	00	60A0D	00	60A0D	00	60A0D	00	60A0D	00
75A	A	75A0A	A2	-	-	-	-	-	-	-	-
75A	D	75A0D	A2	75A0D	A2	75A0D	A2	75A0D	A2	75A0D	A2
80A	A	80A0A	A2	-	-	-	-	-	-	-	-
80A	D	80A0D	A2	80A0D	A2	80A0D	A2	80A0D	A2	80A0D	A2
100A	A	100AA	00	-	-	-	-	-	-	-	-
100A	D	100AD	00	100AD	00	100AD	00	100AD	00	100AD	00
120A	A	120AA	A2	-	-	-	-	-	-	-	-
120A	D	120AD	A2	-	-	-	-	-	-	-	-
125A	A	125AA	A2	-	-	-	-	-	-	-	-
125A	D	125AD	A2	125AD	A2	-	-	125AD	A2	125AD	A2
150A	A	150AA	00	-	-	-	-	-	-	-	-
150A	D	150AD	00	150AD	00	150AD	00	150AD	00	150AD	00
160A	A	160AA	A2	-	-	-	-	-	-	-	-
160A	D	160AD	A2	160AD	A2	160AD	A2	160AD	A2	160AD	A2
200A	A	200AA	A2	-	-	-	-	-	-	-	-
200A	D	200AD	A2	200AD	A2	200AD	A2	-	-	200AD	A2
200A, based on 250A	B	200AB	B1	200AB	B1	200AB	B1	200AB	B1	200AB	B1
240A, based on 250A	B	240AB	B1	-	-	-	-	-	-	-	-
250A	B	250AB	00	250AB	00	250AB	00	250AB	00	250AB	00
300A, based on 250A	B	300AB	B1	300AB	B1	300AB	B1	300AB	B1	300AB	B1
300A, based on 400A	B	300AB	B2	300AB	B2	300AB	B2	300AB	B2	300AB	B2
350A, based on 400A	B	350AB	B2	-	-	-	-	-	-	-	-
400A	B	400AB	00	400AB	00	400AB	00	400AB	00	400AB	00
500A, based on 400A	B	500AB	B2	500AB	B2	500AB	B2	500AB	B2	500AB	B2
500A, based on 600A	B	500AB	B3	500AB	B3	500AB	B3	500AB	B3	500AB	B3
600A	B	600AB	00	600AB	00	600AB	00	600AB	00	600AB	00
650A	B	650AB	B3	-	-	-	-	-	-	-	-
750A, based on 600A	B	750AB	B3	750AB	B3	750AB	B3	-	-	750AB	B3
750A, based on 1000A	B	750AB	B4	750AB	B4	750AB	B4	750AB	B4	750AB	B4

Export department:
 English: +48 68 45 75
 139/ 233/ 321/ 386
 e-mail: export@lumel.com.pl

LUMEL S.A.
 ul. Sulechowska 1
 65-022 Zielona Góra
 POLAND
WWW.LUMEL.COM.PL

B2, B3, B4, B5, B6 MEASURING SHUNTS

Measuring range	Version (drawing)	B2 60mV		B3 150mV		B4 50mV		B5 75mV		B6 100mV	
		Range code	Version code	Range code	Version code	Range code	Version code	Range code	Version code	Range code	Version code
800A, based on 600A	B	800AB	B3	800AB	B3	800AB	B3	-	-	800AB	B3
800A, based on 1000A	B	800AB	B4	800AB	B4	800AB	B4	800AB	B4	800AB	B4
1kA	B	1k00B	00	1k00B	00	1k00B	00	1k00B	00	1k00B	00
1.2kA, based on 1kA	B	1k20B	B4	1k20B	B4	-	-	1k20B	B4	1k20B	B4
1.2kA, based on 1.5kA	B	1k20B	B5	-	-	-	-	1k20B	B5	1k20B	B5
1.2kA, based on 1.5kA	C	-	-	1k20C	C1	-	-	-	-	-	-
1.5kA	B	1k50B	00	1k50C	00	1k50B	00	1k50B	00	1k50B	00
2kA, based on 1.5kA	B	2k00B	B5	-	-	2k00B	B5	2k00B	B5	2k00B	B5
2kA, based on 1.5kA	C	-	-	2k00C	C1	-	-	-	-	-	-
2kA, based on 2.5kA	B	2k00B	B6	-	-	2k00B	B6	-	-	-	-
2kA, based on 2.5kA	C	-	-	2k00C	C2	-	-	2k00C	C1	2k00C	C1
2.5kA	B	2k50B	00	-	-	2k50B	00	-	-	-	-
2.5kA	C	-	-	2k50C	00	-	-	2k50C	00	2k50C	00
3kA, based on 2.5kA	B	3k00B	B6	-	-	3k00B	B6	-	-	-	-
3kA, based on 2.5kA	C	-	-	3k00C	C2	3k00C	C1	3k00C	C1	3k00C	C1
3kA, based on 4kA	C	3k00C	C1	3k00C	C3	-	-	3k00C	C2	3k00C	C2
4kA	C	4k00C	00	4k00C	00	4k00C	00	4k00C	00	4k00C	00
5kA, based on 4kA	C	5k00C	C1	5k00C	C3	5k00C	C1	5k00C	C2	5k00C	C2
5kA, based on 6kA	C	5k00C	C2	5k00C	C4	5k00C	C2	5k00C	C3	5k00C	C3
6kA	C	6k00C	00	6k00C	00	6k00C	00	6k00C	00	6k00C	00
8kA, based on 6kA	C	8k00C	C2	8k00C	C4	8k00C	C2	8k00C	C3	8k00C	C3
8kA, based on 10kA	C	8k00C	C3	8k00C	C5	8k00C	C3	8k00C	C4	8k00C	C4
10kA	C	10k0C	00	10k0C	00	10k0C	00	10k0C	00	10k0C	00
12kA, based on 10kA	C	12k0C	C3	-	-	12k0C	C3	-	-	-	-
12kA, based on 15kA	C	12k0C	C4	-	-	12k0C	C4	-	-	-	-
15kA	C	15k0C	00	15k0C	00	15k0C	00	15k0C	00	15k0C	00
18kA, based on 15kA	C	18k0C	C4	-	-	-	-	-	-	-	-

SEE ALSO:



Universal transducer of temperature and standard signals P300

Export department:
English: +48 68 45 75
139/ 233/ 321/ 386
e-mail: export@lumel.com.pl

LUMEL S.A.
ul. Sulechowska 1
65-022 Zielona Góra
POLAND
WWW.LUMEL.COM.PL