



control with μ WiFi technology
from any place in the World



WIRELESS CONTROLLER FOR ROLLER SHUTTERS 230V, DIN RAIL MOUNT

ability to control by voice commands
with Amazon Alexa and Google Home



SAFETY RULES

- Do not connect the device to loads exceeding the permitted values.
- Connect only in accordance with the diagram presented in the manual. Improper connections may be dangerous, it can damage the controller, and loss of the warranty.
- DANGER!** Risk of electric shock! Even with the device turned off, the outputs may be live. All assembly work should be **ALWAYS** performed with the disconnected power circuit.
- The installation of the device to a power mains that does not meet the quality requirements defined by PN-EN 50160, will result in the loss of the warranty.
- Protect the power circuit with overcurrent protection.

1 INSTALLATION - BASICS

- Disconnect the installation supply voltage before installing the controller. Remember that any mounting works should be carried out when the mains voltage is disconnected (switch off the mains fuse or disconnect the power cord from the mains socket).
- The controller should be installed on the DIN rail, protected from third party access - in the flush box or inside the enclosure of the controlled device. Remember that metallic elements (wires, housing parts) have a negative influence on the range of the device, and consequently the comfort of use. It is recommended that the device be mounted in a stable and fixed position. Due to the operating voltage of the device it is necessary that the connectors of the controller be protected against accidental contacts or short circuits, which could cause electric shock or damage to the device.

CONNECTION DIAGRAMS

1. General connection - common neutral wire

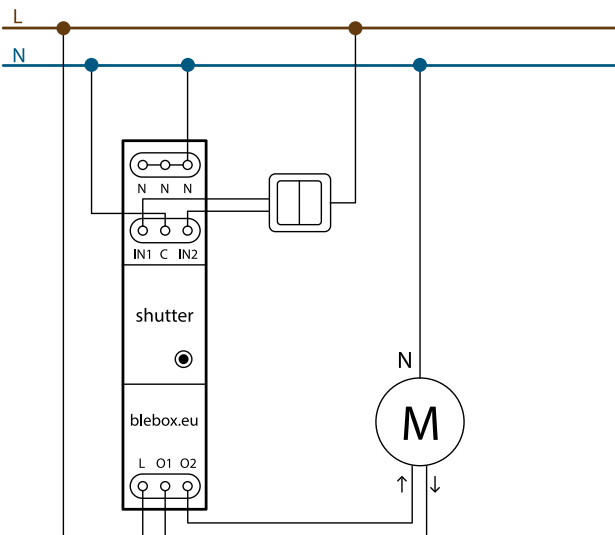

2. General connection - common phase wire

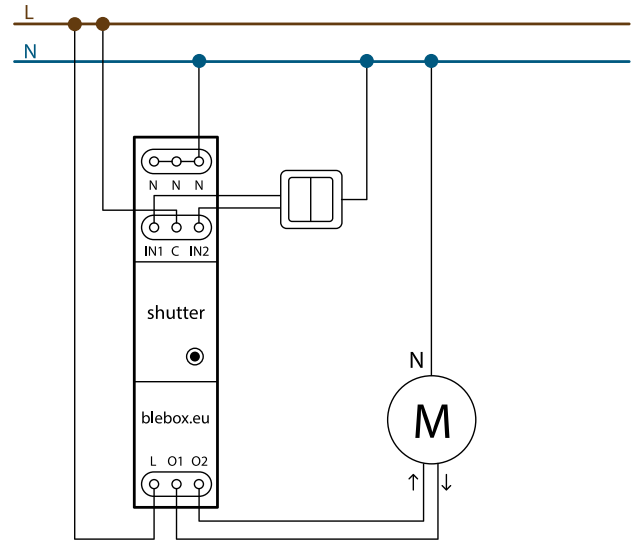

3. Connecting additional button

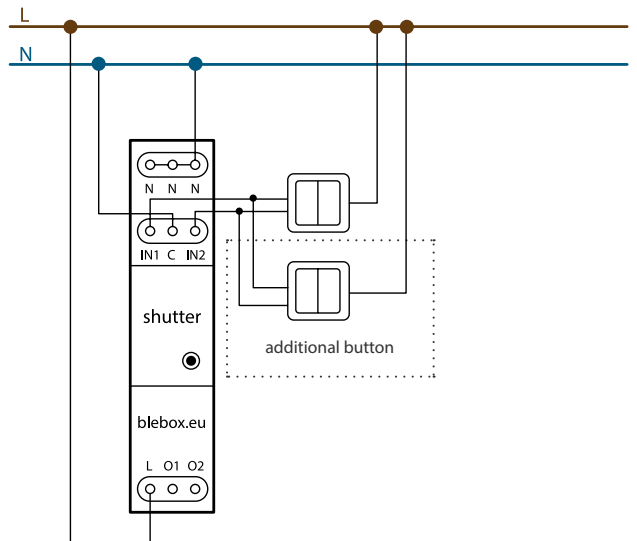

4. Connection of sensors with a relay output (e.g. motion detector, smoke detector, water level detector)

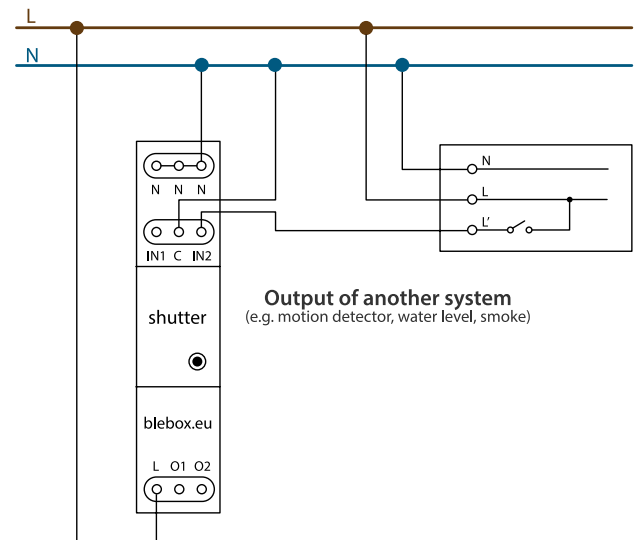

Output of another system
(e.g. motion detector, water level, smoke)

5. Integration with an alarm system or other automation system

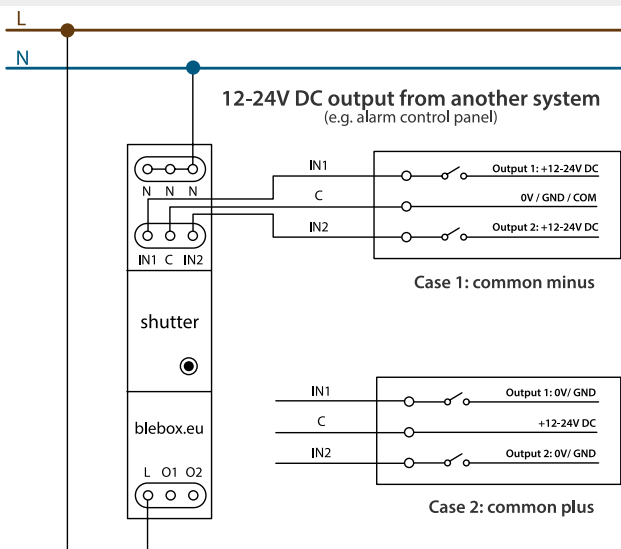

- Read the diagram and then proceed to install the controller. Pay particular attention to the designation of the controller connectors. Start with power wires - phase L (usually brown) and neutral N (blue). Then, connect the load. If you only want a local control with a wall switch, connect the wall push-button according to the diagram. To control using only your phone or Tablet, it is not necessary to install the wall push-button.
- The controller supports double monostable (bell) switches without backlight. The order of connecting the S1/S2 input to the right/left switch button does not matter at the installation stage - it can be set at a later stage of the controller configuration.
- After making sure that the device is connected in accordance with the diagram and that there are no metal components near the controller which may accidentally cause short-circuit, start the device by turning on the power (turning on the mains fuse or connecting the power cord to the power outlet).



Devices mounted on a DIN rail can generate significant amounts of heat. It is recommended to install with a distance of at least 1 cm between BleBox DIN modules to ensure adequate air flow. In the case of using many DIN modules, it is recommended to force the air circulation in the switchboard mechanically.

2

FIRST START

- Download the **free wBox application**. If you have an Android mobile device, you will find the application in the Play Store. For iOS devices the application is in the App Store.
- By using your mobile phone or tablet, connect it to the device wireless network. To do this, go to your smartphone or tablet settings, then go to setting of the WiFi network and find the network name „shutterBox_DIN-xxxxxxxxx” where xxxxxxxxxxx is the serial number of the device. Connect to this network.
- Turn on the wBox application. You will see your device on the main screen. In order to add it to your application account, select “Add device to account”. If you are the installer and do not want to assign the device to your account, select “Use only once”.



You can also set the configuration using the web browser of your phone / tablet. After connecting to the wireless network of the controller, turn on the browser and go website www.blebox.eu

- Test the controller's work by clicking on the arrow near to the area showing the window. If the electric shutter is moving in a different direction than you suppose to go to „Settings” (icon at the top-right corner of the screen) and change the “Move direction swap” option in “Device settings” section. Remember to save your settings by clicking the “Save” button, then go to the main panel by clicking the arrow at the top-left corner of the screen. Check again whether the shutter moves as expected.
- If you have connected the wall push-button, check its work. Single pressing of the “down” button / “up” button will cause that the roller shutters moves in the desired direction to the end position. If the electric shutter goes in the opposite direction to the expected, turn on the “Buttons swap” option in “Device settings” section. When the electric shutter is moving, pressing any of the wall switches causes that the shutter will stop immediately.

- The next step is to select the type of roller shutter to be controlled - in settings under “Control type”, select one of the options: “Roller shutter”, “Tilt shutter”, “Window opener”, “Textile shutter”, “Awning” or “Screen”. The individual options differ by the control algorithm (among others, the conversion of the set position to the time of movement) and the icon on the control screen. If you have an unusual engine, select the “Without positioning” option. Specify also the maximum time of movement which is needed for the transition between end positions - this is the time in which the controller gives voltage to the roller motor (it is not recommended to turn off the move timeout). A suggested value of 120 seconds is sufficient for most motors. The “Tilt shutter” option is designed for controlling tilt shutters with steerable slats rotated by a single motor. After selecting this option, it is also necessary to set an additional field “Time of maximal rotation of the slats in milliseconds” (suggested value approx. 1100 ms). This is the time in which the slats will be in the maximum angle of the rotation before the shutter starts rolling - thanks to this the adjustment of both the position of the blind and angle of the slats by the additional scrollbar can be done at the control screen.
- To move the eg. roller shutter to the specific position, the controller should be calibrated by clicking the “Automatic calibration” button. To use this feature, calibrate the controller by clicking the “Auto calibration” button. Once the procedure is confirmed, the electric shutter will open to the upper limit switch position, then will close to the lower limit switch position and then will open again to the upper limit switch position. During the calibration, do not perform any action. To check the work of the control to a certain point, go to the main panel by clicking the arrow at the top-left corner and then by moving the finger several times over the area showing the window in extreme and intermediate positions, verify if the electric shutter moves to the selected position in the animation. You can also set your electric shutter position - to do this, set the electric shutter in the desired position and then hold the heart icon for about 4 seconds. Then verify the functionality - moving the electric shutter to another position, then click on the heart icon. The electric shutter should be placed in your favorite position.
- The motors have a different design, some of them are equipped with electromechanical limit switches, others with electronic sensors. If the automatic calibration does not work properly, evaluate the value of the “Limit switch detection threshold” field in the “Device settings” section of the device settings. The threshold value is in VA and should be less than the power drawn by the motor during its normal operation. If, during calibration, the motor stops after a few seconds from the movement start, the value of the action threshold should be lowered, while if the motor runs only one pass (i.e. only up or only down) the value should be increased.

3

WiFi CONNECTION AND SERVICE CONNECTION (AP) SETTINGS

- Go to the WiFi network settings (“Settings” icon in the top right corner of the screen, “Connection” section), where you can connect the device to the home WiFi network to be able to control the device via it or from anywhere in the world. To do this, select the network name from the list of available networks and press “Connect”. If required, enter your WiFi password. When connecting the device to the home network, the phone / tablet may disconnect from the device's network.
- After reconnecting the phone to the controller's WiFi network, check the “WiFi Client status” and “Remote access status” fields. The controller is equipped with a network connection supervision system which in case of problems with connection to the WiFi or the Internet will report the problem and its possible causes. If the network is working properly both fields will be set to “Connected”.
- In order to communicate with the device from outside the local WiFi network, from anywhere in the world, via the wBox application, the device automatically connects to the BleBox cloud system service by default. The remote access system is fully encrypted and secure, the data are transmitted by European servers from reputable companies. It is possible to disable the remote access service - after clicking the “Configure” button, toggle the switch next to the “Remote access” option. Remember that disabling “Remote access” will result in no access to the controller from outside the local network as well as disabling the notifications and external integration systems, therefore we recommend that you leave this option enabled (default setting). event log
- Enabling the “Event log” option will cause the device to record events (e.g. about sent notifications set in the “Actions” section) in the BleBox cloud system. This allows the history of the events to be viewed later also when the controller is offline.
- After completing the WiFi network configuration, you can disconnect from the device network and connect the phone / tablet directly to your home WiFi network. Control from the wBox application will work in the same way as when the phone / tablet is connected to the device's network. If as a user you leave the local network, eg leaving your home or enclosing mobile data, the wBox application will signal this status as “Remote mode”. In this case, you will have access to the device data, but for security reasons settings options will not be available.



- In the "Service connection (AP)" section, you can change the name and give the password of the WiFi network emitted by the device. Remember that changing the network name or password can cause disconnection with the device immediately after clicking the "Save" button, so you should reconnect to the WiFi network.
- It is also possible to completely disable the access point emitted by the device. To do this move the "Access point" slider to the off position and confirm the selection with the "Save" button.

Attention! If the controller does not have a stable connection to the WiFi network ("WiFi client status": "Connected", without any error warnings), restarting the access point will not be possible - in this situation, the only solution is to reset the controller to the factory settings. Disabling the access point is recommended only after the complete driver configuration and making sure that the entire system is working properly.

4 DEVICE SETTINGS

- Go to the device settings (the "Settings" icon in the top right corner of the screen). In the "Name and icon" section you can change the name of the device under which it is displayed in the wBox application.

5 TIME AND LOCATION OF THE DEVICE

- Go to settings, to the "Time and location" section. In the "Device time" tab, select your region and location from the list, confirming the changes with the "Save" button. The device will synchronize its time with the NTP time server (if the controller is in a WiFi network with Internet access) or will download the time from the phone / tablet. Since the controller does not have a clock backup battery, the clock resets itself when the power is disconnected. Hence, it is recommended that the controller is always connected to a WiFi network with internet access so that it can automatically synchronize its clock. This is especially important in controllers that have the function of working with the schedule.
- You can specify the location of the controller using your smartphone or tablet. In the "Device location" tab click the "Set location" button. The application will ask whether to share the location - allow. The approximate coordinates of your location should appear in the "Coordinates" box. If the "Set location" button flashes red with "Error" or the "Coordinates" field has not changed the value from "Not set" to numerical data there has been a failure in retrieving the location. You should then make sure that the phone / tablet has a GPS module and that the wBox application has access rights to download the location in the phone settings. Setting the location is especially important in controllers that have the function of working with the schedule, in which the schedule is based on sunrise and sunset.

TECHNICAL SPECIFICATIONS	
supply voltage	230V AC
controller energy consumption	< 1W
number of outputs	2
type of outputs	relay, push-pull, short-circuited to L
maximum load	per output: 5A
maximum power	per output: AC1 (resistive, $\cos\varphi > 0.95$): 5A @ 230V AC = 1150W AC3 (IEC60947-4-1): ~ 0.15kW @ 240V AC (motor)
number of inputs	2
inputs type	optoisolated, logical, configurable, 12-230V AC / DC

supported switches	monostable (push-button), bistable (traditional, cross switch), not-illuminated
number of buttons	1
buttons type	tact-switch, on / off function
status signaling	backlight
housing type	installation module DIN-1, width 17.5mm
dimensions	90(98,8) x 17,5 x 64,5mm
protection level	IP20 according to PN-EN 60529
housing	ABS / acrylic, flammability class V-0 according to UL 94
mounting method	direct mounting on a 35mm DIN rail according to PN-EN 60715
communication standard	μWiFi, compatible with WiFi, 802.11g
radio frequency	2.4 GHz
transmission type	two-way, encrypted
API	open
mode	direct connection (as an Access Point), WiFi connection via a standard router, connection with access from anywhere in the world (only Internet access required)
compatible devices and systems	Apple iPhone, Apple iPad, iPad Mini, Android, computers and mobile devices supporting HTML5
controller operating temperature	from -20°C to +50°C

ADDITIONAL INFORMATION

SCHEDULE

The controller has the ability to work according to a given schedule.

Adding schedule entries can be performed by clicking the "Add item" button in the "Schedule" section of settings. You can select the days in which the task will be performed, the type of entry (at a specific time, or relative to sunrise / sunset - only having a correctly set location) and set the parameters of the task. The set tasks will be visible as a list, individual entries can be edited, deleted or temporary disabled.

SOFTWARE UPDATE

In order to update the software in the controller it must be connected to the home WiFi network (see "WiFi connection settings" section) which is connected to the Internet. Go to settings, to the "Details, update and help" section and click the "Check for update" button. If an update is available the button changes to "Download new software". After clicking it, wait about 1 minute without closing the interface or taking any other actions. The device will download the latest software and then reboot. You can read the device ID, hardware and software versions in the device details.

HELP

The latest versions of the manual, additional informations and materials about products are available on our website: blebox.eu

General questions: info@blebox.eu. Service and technical support: support@blebox.eu

Before contacting our service, if it is possible, prepare the "Service key" of the given controller available in its settings, in the "Details, update and help" tab. By clicking the icon, the key will be copied to the phone's clipboard. Prepare also the "Installation key" of the wBox application, available in the main application menu, in the "Settings" tab.

Factory reset manual is available at: blebox.eu/start/reset

Attention! Factory reset does not remove the controller from the user account assigned to it. The device must be independently removed from the account - select "Manage devices" from the main menu of the wBox application, then select the device and click the "Remove device" button. Alternatively, you can log into the portal.blebox.eu system, go to the "Devices" tab, choose the device and select "Remove device" from the top-right "Actions" menu.

for more information visit our website

www.blebox.eu

or send us an email to: info@blebox.eu

support is available at support@blebox.eu

made in Europe



proudly made by
blebox

