

20W

AC-DC POWER SUPPLIES

The EHL20 series of PCB mount single output power supplies deliver 20W of power and offer single output voltages ranging from 3.3V to 48VDC. The EHL20 series is available in both open-frame and encapsulated mechanical formats. These high power-density power supplies feature a wide 85 to 528VAC input, specifically designed for phase-to-phase operation in a 480VAC system.

The EHL20 series also offers OVC III compliance, Class II construction, worldwide industrial and household safety approvals, making it suitable for a wide range of industrial applications and control systems in commercial and residential buildings.



Features

- Phase to neutral or phase to phase operation
- Overvoltage category III
- Wide 85 to 528VAC input range
- Single voltage outputs from 3.3V to 48VDC
- Encapsulated or open-frame formats
- IEC Class II construction
- Industrial and household safety approvals
- -25°C to +70°C operating temperature
- 3 year warranty

Applications



Industrial
Electronics &
Robotics



Security



3 Phase
Power Supplies

Dimensions

EHL20:

69.9 x 47.0 x 29.2mm (2.75" x 1.85" x 1.15")

EHL20-P:

66.8 x 43.9 x 27.4mm (2.63" x 1.73" x 1.08")

Models & Ratings

Model Number ⁽¹⁾	Output Voltage	Output Current	Efficiency ⁽²⁾	Output Power
EHL20US03	3.3VDC	4.55A	77%	15W
EHL20US05	5.0VDC	4.00A	82%	20W
EHL20US09	9.0VDC	2.22A	85%	20W
EHL20US12	12.0VDC	1.67A	86%	20W
EHL20US15	15.0VDC	1.33A	86%	20W
EHL20US24	24.0VDC	0.83A	88%	20W
EHL20US48	48.0VDC	0.42A	88%	20W

Notes:

1. Open frame version available only for OEM quantities, to specify add suffix -P to model number, e.g. EHL20US12-P.
2. Typical efficiency at 230VAC and full load.

Input

Characteristic	Minimum	Typical	Maximum	Units	Notes & Conditions
Input Voltage Range	85		528	VAC	Derate from 100% at 90VAC to 90% at 85VAC
Input Frequency	47		63	Hz	
Input Current - Full Load		0.37/0.22		A rms	At 115/230VAC
No Load Input Power			0.3	W	
Inrush Current			40	A	At 230VAC, cold start 25°C
Earth Leakage Current	Class II construction no earth				
Input Protection	External 2.0A/600V required				
Overvoltage Category	OVC III				

Output

Characteristic	Minimum	Typical	Maximum	Units	Notes & Conditions
Output Voltage	3.3		48	VDC	
Initial Set Accuracy			1.0	%	
Minimum Load	0			A	No minimum load required
Line Regulation			1	%	
Load Regulation			2		
Start Up Delay			2	s	
Start Up Rise Time			35	ms	
Hold Up Time	8	14		ms	At full load and 115VAC
Transient Response			4	%	Deviation, recovery within 1% in less than 500µs for a 25% load change
Ripple & Noise			100	mV pk-pk	3.3-5V models, 20MHz bandwidth at 25°C
			1	% pk-pk	9V to 48V models, 20MHz bandwidth at 25°C
Overvoltage Protection	110		145	% Vnom	220% typical for 3V3 model, auto recovery
Overload Protection	110		200	%	
Short Circuit Protection	Trip & Restart (hiccup mode)				
Temperature Coefficient			0.05	%/°C	

General

Characteristic	Minimum	Typical	Maximum	Units	Notes & Conditions
Efficiency		85		%	Model dependent
Isolation: Input to Output	4000			VAC	
Switching Frequency	17		80	kHz	Varies with load
Power Density			19.5	W/cm ³	For '-P' version
Mean Time Between Failure	550	600		khrs	MIL-HDBK-217F, +25°C GB
Weight		85 (0.187)		g (lb)	Open frame versions (-P)
		190 (0.419)			Encapsulated version

Environmental

Characteristic	Minimum	Typical	Maximum	Units	Notes & Conditions
Operating Temperature	-25		+70	°C	3V3 & 5V models
					Derate output linearly from 100% at +45°C to 40% at +70°C
					Other models
					Derate output linearly from 100% at 55°C to 50% at 70°C
Storage Temperature	-40		+85	°C	
Cooling	Convection-cooled				
Humidity			95	%RH	Non-condensing
Operating Altitude			4000	m	
Shock	IEC68-2-27, 30g, 11ms half sine, 3 times in each of 6 axes				
Vibration	IEC68-2-6, 2g, 10Hz to 500kHz, 10 mins/cycle, 60 mins each cycle				

Efficiency Graphs

EHL20US12-P

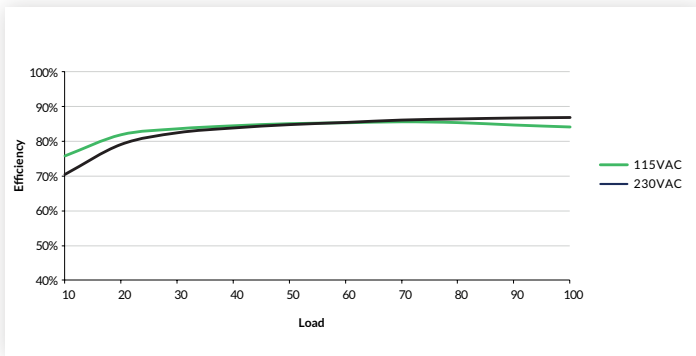

EHL20US24-P

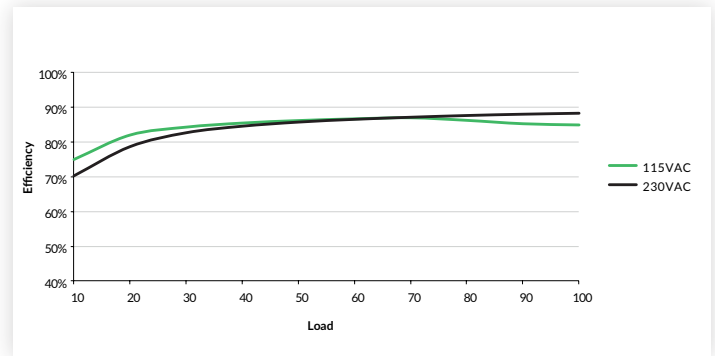

EMC: Emissions

Phenomenon	Standard	Test Level	Notes & Conditions
Conducted	EN55032	Class A/B	Class B with external components, see application notes
Radiated	EN55032	Class B	Class B with external components, see application notes
Harmonic Current	EN61000-3-2	Class A	
Voltage Flicker	EN61000-3-3		

EMC: Immunity

Phenomenon	Standard	Test Level	Criteria	Notes & Conditions
ESD Immunity	EN61000-4-2	±6kV contact, ±8kV air discharge	A	
Radiated Immunity	EN61000-4-3	10 V/m	A	
EFT/Burst	EN61000-4-4	3	A	
Surge	EN61000-4-5	2	A	Line to line
Conducted	EN61000-4-6	10Vrms	A	
Magnetic Fields	EN61000-4-8	10A/m	A	
Dips and Interruptions	EN61000-4-11 (115VAC)	70% U_T (80.5VAC) for 100ms	A	
		40% U_T (46VAC) for 200ms	B	
		<5% U_T (0VAC) for 10ms	A	
		<5% U_T (0VAC) for 5000ms	B	
	EN61000-4-11 (230VAC)	70% U_T (161VAC) for 100 ms	A	
		40% U_T (92VAC) for 200ms	A	
		<5% U_T (0VAC) for 10ms	A	
		<5% U_T (0VAC) for 5000ms	B	

Safety Approvals

Certification	Standard	Notes & Conditions
CB	IEC62368-1	ITE
UL	UL62368-1	ITE
TUV	EN62368-1	ITE
	EN60335-1	Household and similar
CE	Meets all applicable directives	
UKCA	Meets all applicable legislation	

Application Notes

EMC with Output Grounded

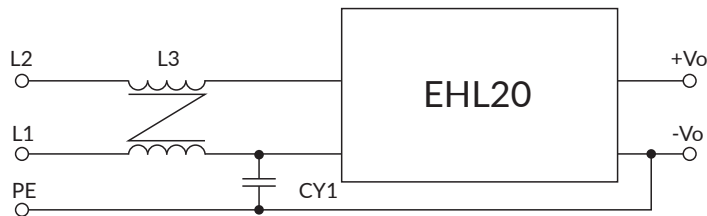

Pin Connections

L3	CMCK DIP UU-9.8 Φ 0.35*60T 10mH (min)
CY1	Y1 CAP 10mm 1000pF/400VAC 20% CDTDK

This product will meet Class A emissions with no external components. For Class B operation, additional components are required.

Mechanical Details

Encapsulated

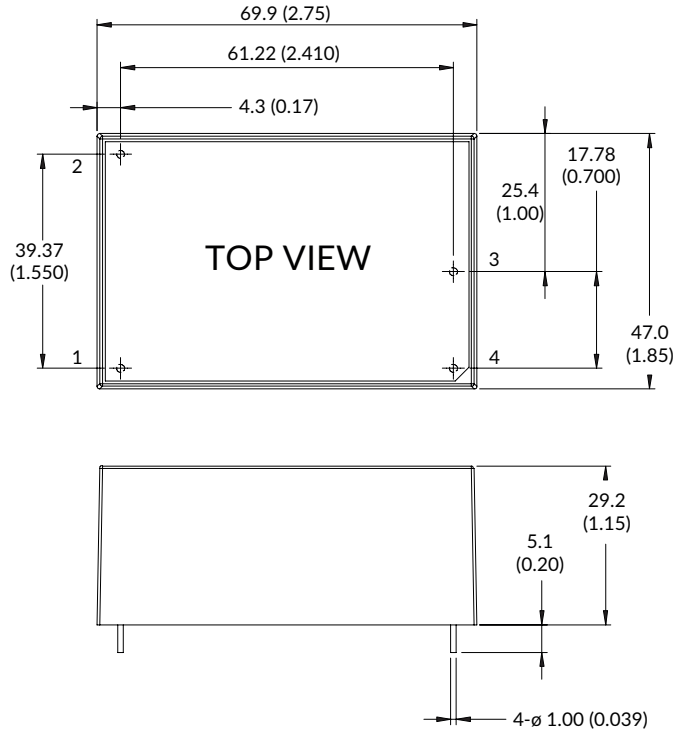

Open Frame (-P)

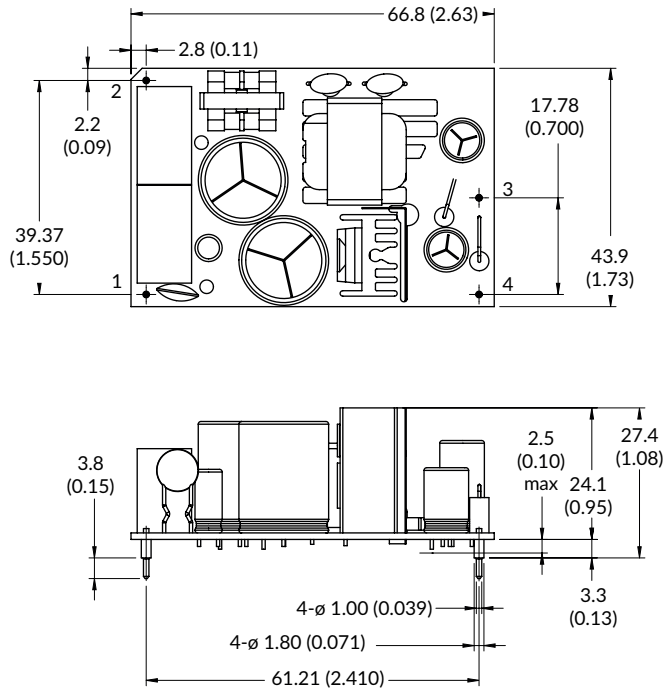

Pin Connections	
Pin	Single
1	L1
2	L2
3	+Vout
4	-Vout

Notes:

1. Dimensions in mm (inches).
2. Weight: Open frame versions (-P): 85g (0.187lbs) Encapsulated: 190g (0.419lbs)
3. Tolerances: x.x = ±0.5 (x.xx = ±0.02) x.xx = ±0.25 (x.xxx = ±0.01)